

COUNTY OF SAN LUIS OBISPO

PARKS AND RECREATION ELEMENT
OF THE SAN LUIS OBISPO COUNTY GENERAL PLAN

PARKS AND RECREATION ELEMENT

ADOPTED BY
THE SAN LUIS OBISPO COUNTY BOARD OF SUPERVISORS
DECEMBER 19, 2006 – RESOLUTION 2006-478

COUNTY OF SAN LUIS OBISPO

Board of Supervisors

Harry Ovitt, District 1
Shirley Bianchi, District 2
Jerry Lenthall, District 3
Katcho Achadjian, District 4
James Patterson, District 5

Planning Commission

Bob Roos, District 1
Bruce Gibson, District 2
Penny Rappa, District 3
Eugene Mehlschau, District 4
Sarah Christie, District 5

Parks and Recreation Commission

Dorothy Jennings, District 1
Pandora Nash-Karner, District 2
Terry Eberhardt, District 3
Paul Teixeira, District 4
Rick Mathews, District 5

County Parks

Peter Jenny, Parks Manager
Jan Di Leo, Parks Planner

Department of Planning and Building

Nancy Orton, Project Planner
John Hofschroer, Project Planner
Kami Griffin, Project Planner
Jeffrey Oliveira, Environmental Coordinator
John Kelly, Supervising Mapping and Graphics Technician

Project Development

Chris Wm Clark, Project Manager
David Foote, Landscape Architect
Nicole Carter ~ EIR
Sara Kocher ~ GIS/Cartography
Seth Sutherland ~ GIS

TABLE OF CONTENTS

Mens sana in corpore sano¹ Juvenal

TABLE OF CONTENTS	i
CHAPTER 1: INTRODUCTION.....	1
WHY PARKS AND RECREATION ARE IMPORTANT	1
HISTORY OF COUNTY PARKS	1
MISSION STATEMENT OF THE COUNTY PARKS DIVISION	2
VISION FOR THE FUTURE.....	2
OBJECTIVES AND POLICIES	3
BACKGROUND.....	3
PURPOSE	3
ADOPTION AND PUBLIC INPUT	4
RECREATION RESOURCES.....	4
LEGAL AUTHORITY AND RELATIONSHIP TO OTHER GENERAL PLAN ELEMENTS.....	5
CHAPTER 2: PARKS.....	7
VALUE AND BENEFITS OF PARKS.....	7
TRADITIONAL TYPES OF PARKS.....	9
PARK CLASSIFICATIONS.....	10
EXISTING PARK RESOURCES	12
HOW PARK NEEDS ARE DETERMINED (NRPA AND SLO).....	16
NEED FOR PARKS WITHIN THE COUNTY.....	17
PARKS GOAL, OBJECTIVE, AND POLICIES.....	19
CHAPTER 3: RECREATION	21
VALUE AND BENEFITS OF RECREATION	21
RECREATION DEFINED.....	21
RECREATION OFFERED BY THE COUNTY.....	22
RECREATION OFFERED BY OUR CITIES	23
PRIVATE RECREATION	24
HOW RECREATION NEED IS DETERMINED	24
HOW RECREATION IS PROVIDED	24
RECREATION GOAL, OBJECTIVES AND POLICIES.....	26
CHAPTER 4: SPECIAL PLACES AND USES	31
SPECIAL PLACES	31
TYPES OF SPECIAL PLACES	31
SPECIAL PLACES AND FACILITIES	31
SPECIAL PLACES GOAL, OBJECTIVES, AND POLICIES.....	33
CHAPTER 5: CHOOSING PARKS AND RECREATION	35
DECISION PROCESS	35
PARKS AND RECREATION COMMISSION.....	35
DECISION TREE	36
CHOOSING PARKS AND RECREATION GOAL, OBJECTIVE, AND POLICIES.....	38
CHAPTER 6: FUNDING & MAINTENANCE	39
INTRODUCTION	39
FUNDING ACQUISITION AND DEVELOPMENT.....	40
FUNDING MAINTENANCE	41
THE PROBLEM	42
SOLUTIONS.....	43
FUNDING ACQUISITION, DEVELOPMENT & MAINTENANCE GOALS, OBJECTIVES, AND POLICIES	45

¹ A healthy mind and a healthy body

CHAPTER 7: DEFINITIONS	47
CHAPTER 8: PARKS AND RECREATION PROJECT LIST	51

Appendices

Appendix A ... California Recreational Use Statute	A-1
Appendix B .. Trail Standards	B-1
PEDESTRIAN TRAIL STANDARDS.....	B-1
BIKE TRAILS STANDARDS.....	B-3
HORSE TRAILS STANDARDS	B-5
MULTI USE TRAIL STANDARDS.....	B-7
TRAIL AMENITIES DESIGN STANDARDS	B-9
Appendix C... Funding Sources.....	C-1
EXISTING SOURCES	C-1
POTENTIAL SOURCES	C-2
Appendix D ... Capital Project Rating Criteria for San Luis Obispo County Parks	D-1
Appendix E Consolidated Goals, Objectives and Policies.....	E-1
MISSION STATEMENT	E-1
CHAPTER 1 – PARKS DIVISION VISIONS FOR THE FUTURE	E-1
PARKS GOAL, OBJECTIVE, AND POLICIES.....	E-1
RECREATION GOAL, OBJECTIVES AND POLICIES	E-3
SPECIAL PLACES GOAL, OBJECTIVES, AND POLICIES.....	E-7
CHOOSING PARKS AND RECREATION GOAL, OBJECTIVE, AND POLICIES.....	E-8
FUNDING ACQUISITION, DEVELOPMENT & MAINTENANCE GOALS, OBJECTIVES, AND POLICIES	E-9
Appendix F Standard Mitigation Measures	F-1

This document is the result of a collaborative effort by a wide range of County staff, community members, and professional consultants. Over the course of several years and countless meetings throughout the county, projects and programs were crafted from the many proposals offered by the community. As with most such policy documents, it was not practical to reach unanimous agreement on all issues, but through the collaborative process of consensus-building, a balanced approach that will service the community for years to come was achieved. While many of the key players are noted on the acknowledgement plate, we would be remiss if we did not single out the efforts of Senior Park Planner Jan Di Leo who steadfastly rode herd over this major undertaking. Her patience (and at times impatience), professional experience and sense of professionalism, good humor, and dogged perseverance kept this program on track despite the many conflicts and roadblocks encountered along the way. The people of San Luis Obispo County owe a debt of thanks to Jan for her fine work.

Pete Jenny; Parks Manager

CHAPTER 1: INTRODUCTION

The bow that's always bent will quickly break;
But if unstrung 'twill serve you at your need.
So let the mind some relaxation take
To come back to its task with fresher heed.
Phaedrus

Why Parks and Recreation are Important

Recreation and exercise are fundamental to a healthy life. The benefits include greater productivity, less disease, and a brighter future. As the population grows, competition for recreational resources increases. Wide open spaces, once the haven of the equestrian, hiker and poet, are more often fenced and the right of exclusivity enforced. As the development and formality of our area increases, so must the provision of recreation spaces that are available to all people.



Oak Trees at Nipomo Community Park

Children are the greatest beneficiaries of recreation. The lessons are legion: cooperative competition, character building, physical and mental health, and an opportunity to escape electronic entertainment.

According to the National Institutes of Health, recreation and exercise result in:

- more energy and capacity for work and leisure activities
- greater resistance to stress, disease, anxiety, fatigue, and a better outlook on life
- increased stamina, strength and flexibility
- improved efficiency of the heart and lungs
- loss of extra pounds or body fat
- help in staying a desirable weight
- reduced risk of heart attack

History of County Parks

The County of San Luis Obispo formally began its responsibility for managing parks in 1929 when the budget first included a line item for "miscellaneous" expenses associated with "beach parks." By 1932 the County's budget

included funds for "County Parks" and for the next five decades, the Department of Parks and Beaches grew in size and complexity.

By the early 1980s the County was faced with declining revenues in the wake of California's well-known Proposition 13. Following a trend seen throughout the state, County government was reorganized in an attempt to reduce costs. Parks and Beaches were consolidated into the newly formed Department of General Services where it is located today.

By 2006, County Parks consists of two major divisions: Parks and Golf. Park facilities range from very large regional parks that are thousands of acres in size down to coastal access ways that occupy a fraction of an acre. In between are such diverse facilities as bike trails, an historic adobe and a geographically diverse system of community parks.

The Golf program is currently comprised of three championship-style, 18-hole courses. These golf courses are as diverse as the park system. Morro Bay Golf Course is actually part of Morro Bay State Park but is now entering its second half-century under County management. In 1980, recognizing the need for public golf facilities in the north county, Chalk Mountain Golf Course was opened. Most recently, the County opened Dairy Creek Golf Course in 1997 to meet the growing demand for more play and relieve some of the strain on Morro Bay Golf Course which had reached its capacity.

Today, County parks and golf courses play host to over 3.2 million annual visitors.

Mission Statement of the County Parks Division

The mission of the Parks Division is to ensure diversified opportunities for recreation and the personal enrichment of the county's residents and visitors while protecting its natural, cultural and historical resources.

Vision for the Future

San Luis Obispo County desires to have an excellent inventory of parks and recreation facilities. Success depends upon numerous variables such as the availability of land and funding. Moreover, not every member of the community shares the same vision for the future. Considering these challenges, County Parks aspires to provide the following:

1. A quality park, recreation and natural area system.
2. An equitable distribution of parks and recreation lands and services.
3. Parks and recreation opportunities for all age groups and physical capabilities.
4. A system of parks, recreation and natural areas consistent with the community's existing and future needs.



"What better places to begin healing than in our parks, where Americans can draw strength from icons of freedom and peace from splendors of nature."

Interior Secretary Gale Norton

5. Protection of sensitive natural and cultural resources within new and existing parks and natural areas.
6. A viable park, recreation and natural area funding source which provides for community needs.

Objectives and Policies

The objectives and policies in this Element are set out in each chapter.

Background

The Parks and Recreation Element is an optional component of the County's General Plan. The County has had a Recreation Element as part of its General Plan since 1968. The adoption of the original Recreation Element shows an early commitment, on the part of the County, to providing adequate park and recreation opportunities for both residents and visitors. This also recognizes the important role parks play in the make-up of the county's quality of life.

In 1987, the Board of Supervisors authorized the preparation of a Parks and Recreation Master Plan. The Board adopted the Master Plan in 1988. Additionally, the Board adopted a County Trails Plan in 1991 and a Natural Areas Plan in 1992. While these documents do not have the legal authority of a General Plan element, they have guided park and recreation development in the County since their adoption.

This document updates and replaces the Recreation Element that was adopted in 1968. It also replaces the policies that were set forth and approved by the Board of Supervisors as part of the 1988 Parks and Recreation Master Plan and the 1991 County Trails Plan. References to the Natural Areas Plan are included in this document and in the Agriculture and Open Space Element of the County General Plan.

This Element establishes goals, policies and implementation measures for management, renovation and expansion of existing, and development of new, parks and recreation facilities in order to meet existing and projected needs and to assure an equitable distribution of parks throughout the county.

Purpose

The purpose of the Parks and Recreation Element is to (1) provide policy guidance regarding the provision of park and recreation services, (2) document the County's existing park and recreation resources, and (3) facilitate the evaluation of park and recreation needs including those



Going no place and wearing a smile

All work and no
play.....

resources that are outside of the County's management during the land use decision process.

The Element does not rezone property, nor does it authorize any public access to lands described here that are currently in private ownership.

Adoption and Public Input

In February of 1993 the Board of Supervisors authorized combining the approved Parks and Recreation Master Plan, Trails Plan and the Recreation Plan into a comprehensive *Parks and Recreation Element*. A series of workshops were held from April to June 1995 in order to receive public comments and these comments became the basis for preparation of the draft plan.

In January 1996, a "Parks Commission Review Draft" was distributed to the Parks and Recreation Commission for a three-month review period. Five public workshops were held throughout the county in order to receive public comment on the proposed Element. After a period of dormancy, the Element update was restarted in 2003. Workshops were again held throughout the County.

The Public Hearing Draft was presented in public hearings before the Planning Commission and the Board of Supervisors in 2006. An Environmental Impact Report was circulated for public review in early 2006. The Environmental Impact Report was certified and the Element was adopted on December 19, 2006 and became effective on January 18, 2007.



Fun with balloons

Recreation Resources

Park facilities and proposals can be found in the following places:

Chapter 8 Project Lists This chapter contains a database of existing and proposed facilities in the County. It includes many of the facilities owned and maintained by the city, state and federal governments. Most of the proposed facilities have not been funded or undergone a master planning process. These represent the desires of our communities and the County in general.

Mapping. Maps have been developed that show existing and proposed facilities. These maps are maintained as part of the County Planning and Building Department's Geographic Information System (GIS). These are maintained by the



Dancing it up with a live band in Templeton

County and can be accessed on the Internet at www.slocountyparks.org or by calling 805-781-5200.

Legal Authority and Relationship to other General Plan Elements

Government Code Section 65300 *et seq.* requires the County to have a General Plan that consists of seven mandatory Elements. In addition to the required Elements, the General Plan may include optional Elements that relate to the physical development of the County. The Parks and Recreation Element is an optional Element. It is an integral part of the General Plan. It has the same force and effect as the other Elements of the General Plan.

State law requires that the General Plan be an internally consistent statement of local government policy. Each Element of the General Plan must be integrated and consistent with all other Elements. This has direct relationships to the Land Use, Conservation, Agriculture and Open Space, and Energy Elements of the General Plan. The policies in this plan are consistent with County General Plan policies and standards.

...it began with Ike, and continues...



President's Council on Physical Fitness and Sports

Executive Order 13265

By the authority vested in me as President by the Constitution and the laws of the United States of America, and to expand the executive branch's program for physical fitness and sports and establish the President's Council on Physical Fitness and Sports, it is hereby ordered as follows:

Section 1. Purpose. The Secretary of Health and Human Services shall, in carrying out his or her responsibilities for public health and human services, develop and coordinate a national program to enhance physical activity and sports participation. Through this program, the Secretary shall seek to:

- (a) expand national interest in and awareness of the benefits of regular physical activity and active sports participation;
- (b) stimulate and enhance coordination of programs within and among the private and public sectors that promote participation in, and safe and easy access to, physical activity and sports;
- (c) expand availability of quality information and guidance regarding physical activity and sports participation;
- (d) integrate physical activity into a broader health-promotion and disease prevention effort through Federal agencies and the private sector; and
- (e) target all Americans, with particular emphasis on children and adolescents, as well as populations or communities in which specific risks or disparities in participation in, access to, or knowledge about the benefits of physical activity have been identified.

THE WHITE HOUSE,
June 6, 2002.

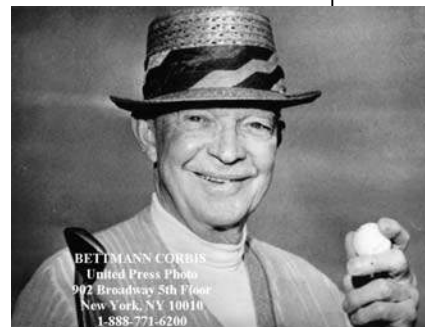

CHAPTER 2: PARKS

A book of verses underneath the bough,
A jug of wine², a loaf of bread, and thou
Beside me singing in the wilderness
Oh, wilderness were paradise enow !
Fitzgerald. Rubaiyat of Omar Khayyam

Value and Benefits of Parks

Our County residents support the improvement of existing parks and the provision of new parks. The 2001 ACTION for Healthy Communities found that the majority of residents polled support the acquisition and development of more public parks and open space.³ The report also found that 63% of residents polled used County parks, trails or beaches on a regular basis.

Beyond the Obvious. Parks and trails contribute to the overall high quality of life and make our communities more livable. As a community we often value parks and recreation opportunities primarily for aesthetic and resource preservation reasons. However, a healthy parks program also provides the community with a variety of substantial health, social and economic benefits.

Health Benefits. Active recreation opportunities are essential for people of all ages to develop and maintain healthy and constructive lifestyles. Our lives can be enriched by experiencing nature, recreating and exercising regularly, and having these experiences close to where we live.



Shade and play field at Nipomo Community Park, an important part of that neighborhood.

During the past 20 years, obesity among adults has risen significantly in the United States. The latest data from the National Center for Health Statistics show that 30 percent of U.S. adults 20 years of age and older—over 60 million people—are obese. This increase is not limited to adults. The percentage of young people who are overweight has more than tripled since 1980. Among children and teens aged 6–19 years, 16 percent (over 9 million young people) are considered overweight. [Source: Centers for Disease Control 2006]

² The County of San Luis Obispo does not endorse or condone the consumption of alcohol at County Parks, but we do endorse “a loaf of bread” and “thou.”

³ ACTION for Healthy Communities is a cooperative, collaborative effort of individual agencies and organizations, public and private, which are committed to improving the overall quality of life of San Luis Obispo County. Research was conducted by Campbell Research of Santa Maria in 2001.

Social Benefits. Organized sports facilities, community centers and group leagues accommodate important cultural activities. Further, the availability and use of active recreation facilities and sports programs have been shown to result in a reduction in juvenile crime rates. Another important aspect of quality of life is the convenient access to natural settings, recreational and cultural opportunities, and open space where individuals and families can spend time together and share common values.

Economic Benefits. Parks make economic sense. The income generated by recreation is of enormous importance to the County's economy. Tourism is the number one industry in our county. The County's parks and recreational opportunities attract literally millions of visitors every year. By contributing to community amenities, parks can also contribute to property values. Studies documented by the National Park Service indicate increased property values in those instances where property is located near or adjacent to natural areas or parks.

Tourism is the county's largest industry, contributing \$1 billion to our local economy each year and providing over 16,000 jobs. The tourist trade also generates approximately \$60 million in sales and hotel taxes for local government. About twelve percent of the county's workforce is engaged in tourism.⁴

Additional Benefits. Parks obtain, incorporate and often conserve important resources and can reduce overall long-term costs to local governments and other public agencies. By thoughtfully establishing a park or trail system to guide people in a sensitive environmental area, we may decrease impacts to adjacent areas and, thus, reduce or eliminate the costs associated with mitigating for those impacts. For instance, retaining riparian areas as a natural area decreases flooding and erosion. In addition, by providing options for alternative modes of transportation, trails and linear parks can reduce the costs associated with auto-dependent transportation.

Parks and recreational programs make a huge difference in reducing crime. A Carnegie Council on Adolescent Development study reveals that 40% of the typical youngster's time is discretionary and available for good and bad choices. Where recreation programs and facilities are available, statistics show crime rates drop. Gang-related problems cost California taxpayers about \$1 billion each year. The typical recreation coordinator costs about half as much as a police officer or prison guard.

Parks, open space, and natural areas are the catalyst for tourism. The San Luis Obispo County Visitors and Conference Bureau's recent Conversion Study show tourists come to our county to "escape." Tourists visit San Luis Obispo County because there are still "wide open spaces" and parks to which urban refugees may "escape." Many tourists spend time in natural areas and parks: 46% participate in wildlife viewing or nature walks; 28% participate in hiking; 17% participate in water sports. Tourists spent \$969.6 million in our County in 2000 for services, commodities, and food. This provides an economic boost for everyone.

⁴ San Luis Obispo County Visitors & Conference Bureau:
http://www.slocountyvcb.org/tourism_stats.htm

Traditional Types of Parks

Parks have been a part of the American landscape since the middle 1800s. Some of the first parks, such as New York City's Central Park, were typically large parks located on the edge of the city. Because transit was expensive and these parks were located far from the center of the city, such parks tended to be too expensive for the average city dweller. At the end of the 19th century, there was an effort to create parks closer to where the majority of city dwellers lived. At the same time, there was advocacy to create safe places for children to play, i.e., other than on city streets. These two movements combined to provide parks for working class people and safe places for children to play.

A surge in school-age population in the 1960s resulted in schools being built at a faster rate than parks. In many communities schools became the *de facto* neighborhood or community park, providing neighborhoods with open play areas and recreation facilities such as basketball courts and large, open turf areas which could be used for baseball and other field sports.

Over time, the typical types of parks located within a community have been named or classified. As towns have become more urban, neighborhoods typically desire a small park close by where one can walk their dog or find adequate lawn area to throw a Frisbee or a baseball. This type of park is often known as *neighborhood park*. More active,⁵ larger parks that typically serve more than one neighborhood and provide a mix of active recreation facilities (such as tennis courts, a swimming pool or even a skateboard park), are known as *community parks*. Parks typically located on the outskirts of town providing facilities that require a large amount of acreage (such as area for camping, golf, nature trails or boating), are known as *regional parks*.

⁵ A distinction is made between active and passive recreation. Active recreation tends to involve recreation facilities and usually larger groups of people. Some examples of active recreation include items such as a community center, a skate park, tennis courts, sports fields, and a swimming pool. Passive recreation tends to be more tranquil and involve recreation activities that involve the individual or a small group. Examples of passive recreation include items such as a walking trail, individual picnic sites, nature appreciation, viewing platforms, and bird watching.



A skater enjoys carving the bowl at the Los Osos Skate Park



Bridge over San Luis Creek at Cuesta Park

Park classifications recognize that a neighborhood park has a different role than a community or regional park. Part of this role is tied to the size of the individual park. For example, a neighborhood park (with a typical size of 5 to 10 acres) simply cannot provide the same recreation or serve as many people as a community park which tends to be 15 to 25 acres in size. Below are the typical park classifications.

Park Classifications

Mini-Parks. Mini-parks is the smallest type of park. They may range in size from a small residential lot, in some cases as small as 6,000 square feet, up to 5 acres. In most cases, mini-parks are usually one acre or less. Because of their small size, mini parks may be more passive in nature. A typical mini-park will include a landscaped area, a short pathway, one to two benches and perhaps a picnic table. Some mini-parks include children's play equipment, a tennis court, half a basketball court, or similar recreation. Mini-parks tends to serve a distinct neighborhood.

In some cases, mini-parks are developed for combined uses. For example, as an area for children's play equipment and the neighborhood's retention basin. Because of their small size, mini-parks have limited recreation potential and have the highest inherent maintenance cost per square foot of any recreation facilities.

Linear Parks. Linear parks are located along a corridor. These parks tend to be narrow and long in configuration. Linear parks may link schools, parks or neighborhoods and may also serve a community's transportation needs. Often a linear park derives its shape by conforming to an edge: of the coast, of a river or creek or an abandoned railroad right-of-way. By their very nature, linear parks lend themselves to trails and bike paths, but also typically provide other recreation amenities such as picnic areas, benches, scenic overlooks, interpretive displays and even play areas and lawns.

Linear parks are most valuable and practical when they preserve and enhance an important corridor or natural edge, or provide a protected, safe corridor between facilities (such as between a school and surrounding neighborhoods).

Neighborhood and Community Parks. Neighborhood and community parks continue to be the primary park units for meeting a community's park and recreation needs. The primary intent of a neighborhood park is to serve a nearby population, typically one or more neighborhoods. According to National Recreation and Parks Association standards, a neighborhood park is 15 or more acres. In general, neighborhood parks are within walking distance from the people they are primarily intended to serve, i.e., one mile or less. Neighborhood parks usually include passive recreation as well as some active recreation. Typical facilities might include children's play equipment, hard courts (such as basketball, tennis or handball), a turf area and individual picnic areas.

By definition, community parks are 25 or more acres, providing recreation facilities that serve the community and in some cases visitors from outside the local community. For example, a community park with numerous sports fields will draw people from a wide area for tournament play. As a result, community parks tend to serve a much larger population than a neighborhood park. Community parks also tend to be more active in nature and/or

provide a greater mix of active recreation. Typical facilities might include a skate park, sports fields (football, baseball, soccer, and softball), a swimming pool, a sufficient number of tennis courts for tournament play, group picnic areas, and/or a community center as well as facilities for some passive uses such as a trails, scenic overlooks, benches and interpretive displays.

Regional Parks. Regional Parks are the largest parks provided by the County. According to the National Recreation and Parks Association, there can be two types of regional parks. In this document we will refer to these as Urban Regional Parks and Rural Regional Parks. The Urban Regional Park tends to have greater than 200 acres, providing facilities such as play areas, picnicking, boating, fishing, swimming, camping and trail use. The Rural Regional Park tends to be 1,000 acres or more. These parks include nature oriented outdoor activities, such as viewing and studying nature, wildlife habitat, conservation, swimming, picnicking, hiking, fishing, boating, camping, and trail use. Both facilities tend to serve persons within one hour's driving time from the park. Urban Regional Parks tend to be closer to urban areas and may serve some of the same park function as a community park. Rural Regional Parks would tend to be more rural in nature, emphasizing nature-oriented activities. Because of the type of recreation provided, regional parks not only draw from the County's population but also from the economically important tourist population. El Chorro, Heilmann and Biddle Park are examples of Urban Regional Parks; whereas, Santa Margarita Lake Regional Park and Lopez Lake Recreation Area would be examples of Rural Regional Parks.

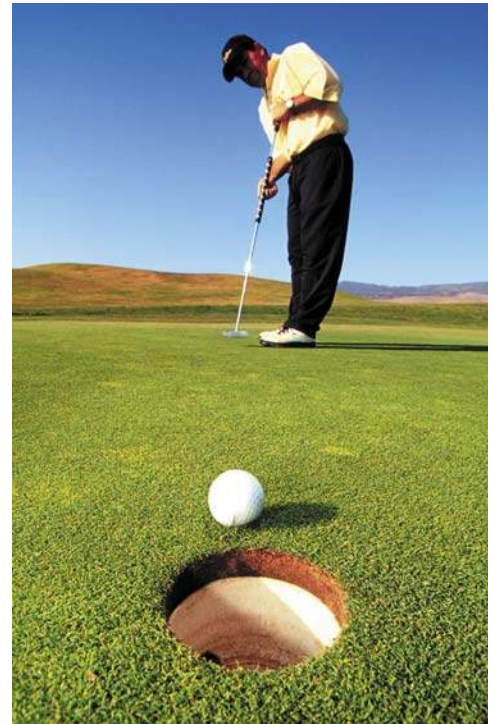

Shooting for par at Dairy Creek Regional Golf Course (photo: Rick Hansen)

Recreation Site. Another setting that is sometimes thought of as a park and/or contains park-like amenities is a site containing a community center or indoor sports facilities. Community centers or indoor sports facilities will often provide an indoor location for recreation such as basketball, fitness classes, crafts, games, and other similar recreation. These sites may also include some outdoor recreation or may simply include a building, parking and exterior landscaping. An example of a recreation site maintained by San Luis Obispo County is the San Luis Obispo Veteran's Memorial Building. This facility offers meeting rooms, music, dances, and an area for small conferences.



Play equipment at El Chorro Regional Park

Existing Park Resources

Provided by San Luis Obispo County. As noted in the following table, there are roughly 23 parks, 3 golf courses, and 8 Special Places⁶ currently operated by County Parks. Urban Regional Parks account for 644 acres, Rural Regional Parks for 11,398 acres, and mini, neighborhood and community parks for 214 acres.

Within the County's unincorporated areas there are very few neighborhood parks. Many of the County's community parks, such as Los Osos Community Park and San Miguel Park, are below ten acres in size and provide the only park facilities in that community. Due to the limited availability of funding for parkland acquisition and maintenance, "community park" status at a particular park often evolved by need rather than original design. By contrast, some of the County's community and regional parks also serve dual functions. For example, regional parks located within or directly adjacent to an urban area often provide a mix of park uses. Nipomo Community Park is an example of a community park that provides neighborhood and community recreation. This 140-acre park is the only developed public park in Nipomo and thus must meet a variety of community needs.

A complete list of the existing County operated parkland and related facilities are found in Chapter 8 Parks and Recreation Project List.

⁶ Special Places include Natural Areas, coastal access, and historic facilities. Natural Area is land protected for its resources which may also afford some passive recreation. Two examples of Natural Areas owned and operated by San Luis Obispo County Parks include the Elfin Forest and Monarch Grove, both located in Los Osos.

Table 1 - County Parks Inventory – March 2006

	Location	Park Acres	Natural Area Acres
Regional Parks (Urban)			
Biddle Park	Arroyo Grande	27	20
Duveneck Park (undeveloped)	Templeton	80	0
El Chorro Park	San Luis Obispo	40	450
Heilmann Park	Atascadero	102	0
Sand and Surf RV Park	Oceano	5	0
Total Regional Parks (Urban)		254	470
Regional Parks (Rural)			
Lopez Lake Recreation Area	Arroyo Grande	200	4,076
Santa Margarita Lake Park	Santa Margarita	21	7,101
Total Regional Park (Rural)		221	11,177
Mini, Neighborhood & Community Parks			
Avila Park/Plaza	Avila	2.5	0
Cuesta Park	San Luis Obispo	5	0
C.W. Clarke Park	Shandon	11.5	0
Hardie Park	Cayucos	4	0
Lampton Cliffs Park	Cambria	2.2	0
Los Osos Community Park	Los Osos	6.2	0
Norma Rose Park (undeveloped)	Cayucos	1.5	0
Nipomo Community Park	Nipomo	74	80
Oceano Memorial Park	Oceano	11.8	0
Paul Andrew Park	Cayucos	1	0
Jack Ready Park (undeveloped)	Nipomo	30	0
San Miguel Park	San Miguel	4.3	0
Santa Margarita Community Park	Santa Margarita	2	0
See Canyon Park (undeveloped)	Avila Valley	8.7	0
Shamel Park	Cambria	6	0
Templeton Park	Templeton	3.5	0
Total Mini, Neighborhood, and Community Parks		174.2	80
Special Places (Natural Areas, Coastal Accessways, Historic Sites)			
Bishop Peak	San Luis Obispo	0	104.3
Cayucos Beach	Cayucos	14	0
Coastal Accessways	Coastal Area	7.3	0
Elfin Forest	Los Osos	0	38.7
Wolf Natural Area	San Miguel	0	58
Monarch Grove	Los Osos	0	18
Mesa Meadows	Nipomo	0	20
Rios Caledonia Adobe	San Miguel	2.8	0
Total Special Places		24.1	239
Golf Courses			
Chalk Mountain GC	Atascadero	212	0
Dairy Creek GC	San Luis Obispo	224	0
Morro Bay GC (State Parks owned, County operated)	Morro Bay	125	0
Total Golf Courses		561	0
Trails and Staging Areas (Outside Parks)			
Bob Jones Pathway	Avila Valley	1.8	0
Cypress Ridge Trail	Nipomo	1	0
Hi Mountain Trail and Staging Areas	Huasna	7	0
San Miguel Staging Area (Salinas River)	San Miguel	2	0
Total Trails		11.8	0
Total Operated Acreage		1,246.1	12,056

Provided by Other Agencies. San Luis Obispo County is not the only agency that provides parks and recreation in San Luis Obispo County. Each incorporated city provides their own system of parks and recreation. Cities, since they serve an urban area, often emphasize active recreation, including recreational programming (recreation classes) as well as neighborhood and community parks. County residents may use city parks typically at no fee. In addition, County residents can typically use a city's recreation programs (recreation classes and league play) for a small, additional fee. Within the unincorporated areas of the County, some Community Services Districts (CSD) provides parks and recreation. For example, the Cambria and Templeton CSDs both provide parks and recreation in their areas.



Cooling off on a hot summer day

Parks are also provided by state and federal agencies. These parks tend to be passive in nature, and thus do not provide items such as soccer fields or tennis courts, but they do provide important areas for nature appreciation and often coastal access. State agencies such as the California Department of Parks and Recreation ("State Parks") provide large, typically passive parks. These parks include items such as trails, camping, access to historic facilities, and/or nature appreciation throughout California as well as San Luis Obispo County. Examples of State Parks facilities within San Luis Obispo County include Hearst San Simeon State Historical Monument, Montaña de Oro State Park, Oceano Dunes State Vehicular Recreational Area, and Morro Bay State Park.

The federal government also provides access to passive parkland. Agencies such as the Bureau of Land Management and the United States Forest Services often provide trail corridors, camping, nature appreciation and in some cases preservation of historic facilities. Examples of federal parks in this area include the Piedras Blancas Light House (near San Simeon), the Carrizo Plains, and the Los Padres National Forest.

Parks and recreation are not only provided by public agencies. Private individuals or groups often provide these services. For example, most communities have a health club that offers items such as weight lifting and fitness classes. In addition, private enterprise may also provide recreation facilities, such as off-highway vehicle parks, paint ball parks, and archery ranges. Throughout the County there are private golf courses (such as Cypress Ridge and Avila Beach Golf Resort) that offer public play. In addition, some residential neighborhoods provide their own private park. The local homeowner's association usually maintains these parks for persons residing in that neighborhood.

A list of many of the facilities managed by the federal government, the state, and the cities in the county can be found in Chapter 8 Parks and Recreation Project List.

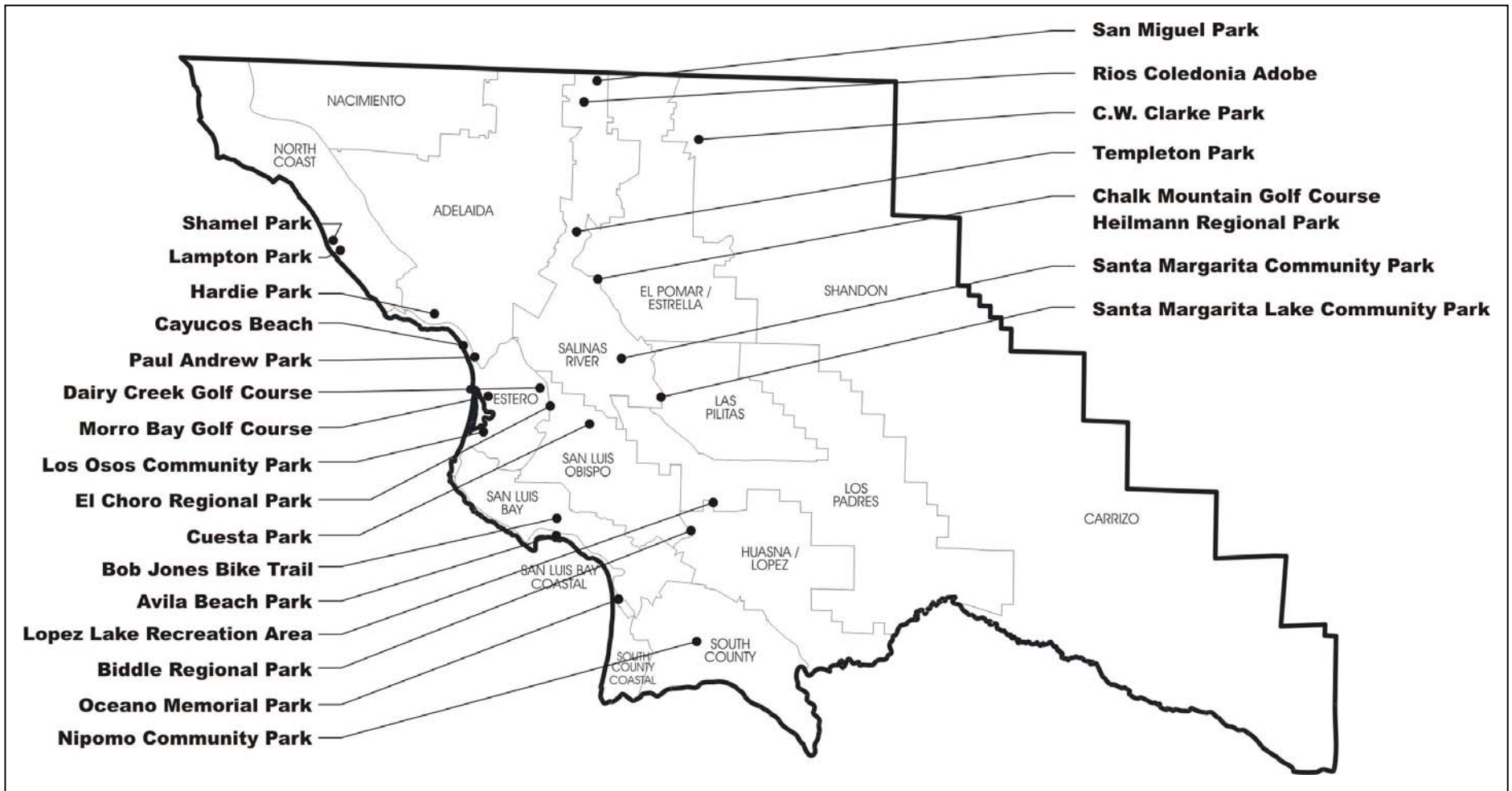

2006 County Operated Park Facilities

How Park Needs are Determined (NRPA and SLO)

In the 1960's and 1970's as urban and suburban populations began to outstrip the ability of many communities to add park lands for its residents, national park standards were developed to help communities plan for adequate park acreage to meet future demand. The standards were expressed in acres of parkland per thousand population.⁷

Table 2 - 1983 National Recreation and Park Association Standards for Parks

CLASSIFICATION	ACRES/1,000 PEOPLE	SIZE RANGE	POPULATION SERVED	SERVICE AREA
Neighborhood Parks	1-2	15+ acres	A Neighborhood Approx. 5,000	1/4 – 1/2 mile
Community Parks	5-8	25+ acres	Several Neighborhoods	1 – 2 miles
Regional Metropolitan Parks	5-10	200+ acres	Several Communities	1 hour driving time
Regional Park Reserve	Variable	1,000+	Several Communities	1 hour driving time
Special Areas	No Applicable Standard	Includes linear parks, trails, beaches, golf courses, historical sites, flood plains, coastal access ways, etc. No standard is applicable.		
Conservancy (Natural Areas)	No Applicable Standard	Protection and management of the natural/cultural environment with recreational use as a secondary objective.		

Experience has shown most communities, including San Luis Obispo County, have not been able to consistently meet these standards. For example, 2005 population for the county would require the immediate acquisition and development of an additional 2,700 acres of local and regional parkland based on traditional park planning standards.

There is a growing recognition that recreation and parkland demand should be met by a host of providers acting in cooperation. Further, planning for parkland acquisition should focus on flexible and adaptive strategies. Communities may be best served by a self-directed approach based on what citizens in a region or community determine is the best and most opportune for themselves. Such a process is described in Chapter 5 Choosing Recreation.



Boats waiting for the wind to pick up at Lopez Lake

⁷ 1983 National Recreation and Park Association Standards for Parks. (These standards are only used for establishing need for additional parklands and facilities. These definitions are not necessarily consistent with specific County Park definitions).

Need For Parks Within The County

While the current National Recreation and Park Association (NRPA) Standards suggest the need for each community to develop its own relevant standards, the 1983 standards do provide a starting point for assessing current need. The following table applies the 1983 NRPA Standards to the County's current inventory.

Table 3 - Application of 1983 NRPA Standards

Facility Type	1983 NRPA Standard (acres/1,000 pop)	2000 Population	Calculated Need (in acres)	Existing Acreage (2003)	Deficiency (in acres)
Neighborhood Park	1-2 acres	103,990	104-208	134 acres ¹	490-906
Community Park	5-8 acres	103,990	520-832		
Regional Metropolitan Park (Urban)	5-10 acres	246,681	1,233-2,466	644 acres	589-1,822
Regional Park Reserve (Rural)	Variable	246,681	N/A	11,398	N/A
Notes: Natural Area acreage is not included in these figures Populations are for urban areas (103,990) and county wide (246,681)					

This Element recommends the development and implementation of local, community park acreage standards based on community input, local surveys and review of state and national trends. Such a localized approach to assessing need is consistent with current NRPA recommendations. That approach may identify the need for additional park acreage in some or all categories, or it may determine that parkland needs are being met. However, in the mean time, the table above provides some indication of how we are doing.

This approach indicates a shortage of neighborhood and community parks, which is consistent with frequently voiced community concerns. If those concerns are to be addressed, it will generally be the County's responsibility in unincorporated communities. Where feasible, special districts, such as the Templeton Community Service District, may provide for this local park need. Another option is to defer unmet needs until the local community incorporates or is annexed by a nearby city. However, this option runs the risk of missing opportunities and defers services to some undetermined future date.

The 1983 NRPA Standards also suggests a shortage of large regional parks near urban areas. These facilities often supplement the active recreation provided by community parks. Once again, local standards will eventually determine specific needs.



Reaching new heights at El Chorro Regional Park

With no applicable acreage standards, the need for additional rural regional parks requires further analysis of community desires and statewide trends. Furthermore, given the importance of tourism to the local economy, an evaluation of the role of rural regional parks should also be considered. Finally, any evaluation must consider that this parkland category may be met by other agencies such as State Parks, the Bureau of Land Management, the National Forest Service or others.

As the population and the number of tourists continue to grow, so will the need for additional parkland. In many communities in the county, land for parks and recreation is at a premium and needs to be acquired or otherwise set aside in a timely fashion before development and rising property values make those acquisition costs prohibitive. The county needs to make every effort to acquire, develop and improve parkland wherever appropriate if it is to keep up with community needs and smart growth.

Perhaps the best indication of how well a community is meeting its park and recreation needs is the ratio of neighborhood and community parkland per 1,000 residents. Table 3, Application of 1983 NRPA Standards refers to a national standard of 5-8 acres of community parkland per 1,000 residents. However, the SLO County 2006 Public Facilities Fee Financing Plan indicates that the County is providing less than 2 acres of neighborhood and community parkland per 1,000. A reasonable goal for the near future is to achieve a minimum of 3 acres of such parkland per 1,000 population in each of the County's unincorporated communities.



Triathlon swimmers emerge from Lopez Lake

Parks Goal, Objective, and Policies

GOAL #1: An equitable and quality public park system within San Luis Obispo County.

OBJECTIVE A: Maintain and improve as well as provide new and expanded parks and recreation within the County consistent with Chapter 8 Parks and Recreation Project List, and the County's available funding.

POLICIES:

2.1 Provide parks which are aesthetic and consistent with community needs.

2.2 When acquiring parkland or considering the acceptance of a parkland donation give first priority to sites that would:

1. Augment needed park or recreation opportunities as defined in this Element.
2. Serve a good mix of users at a reasonable cost.
3. Provide an appreciable amount of parkland or recreation as a result of being adjacent to a compatible site, such as a school.
4. Allow development in a reasonable time period. The County should not obtain lands that have extensive permit and mitigation requirements that may conflict with the project's proposed use(s) or County policy.
5. Serve an important existing or future need. The site should be able to be developed consistent with that need.
6. Accommodate planned uses in terms of size, location, and existing constraints. The property should be largely devoid of constraints or hazards.
7. Adequately accommodate long-term maintenance.
8. Concentrate park acquisition efforts on sites larger than ten acres, except when (a) the proposal is for a linear park connecting important community components or providing key alternative transportation (such as a link between two schools), (b) a proposed park provides the only available park site in a community, (c) another agency will provide maintenance for the park, or (d) a smaller parcel has outstanding characteristics or unique features.

In general, projects that meet these criteria will be given a high priority.

2.3 When developing parkland:

1. Prepare adequate studies to determine site constraints.
2. Prepare and implement a master plan for the site.
3. Provide reasonable buffers between existing uses and the new park facilities in order to reduce impacts.
4. Use joint use opportunities and adopt-a-park programs as they are available.

2.4 Preserve County parkland for active and passive recreation. Community facilities, which have little to no recreational component, shall be placed outside of an existing or proposed park.

2.5 Encourage private development of parklands and facilities, to assist with meeting park needs.

CHAPTER 3: RECREATION

Sweet recreation barred, what doth ensue
But moody and dull melancholy,
Kinsman to grim and comfortless despair;
And at her heels a huge infectious troop
Of pale distemperatures, and foes to life?
Shakespeare, Comedy of Errors

Value and Benefits of Recreation

Parks and recreation are obviously strongly linked. While parks provide the land, recreation is often the amenity provided within the park. Raw parkland and natural areas have value. That value is typically increased when the land also provides amenities that can be used or appreciated.

The recreation provided in a park or natural area may be something as simple as a bench, a meandering trail and an interpretive display, or something as complicated as a skate park or soccer field.



Soccer practice at C. W. Clarke Park

The goal of recreation is multi-faceted. It includes providing a means to appreciate our natural resources, as well as providing exercise and activities for all age groups and all economic backgrounds. As noted in the previous chapter, the benefits of recreation are numerous. Recreation teaches our children values, provides for healthy exercise, and furnishes a format for healthy competition.

Recreation Defined

Recreation is a broad notion and encompasses many enjoyable activities that we use to relax and stay healthy. Typically a distinction is made between active and passive recreation. Active recreation tends to involve facilities and usually larger groups of people. Some examples of active recreation include items such as community centers, a skate park, tennis courts, sports facilities, and a swimming pool.

Passive recreation tends to be more tranquil and involve activities that are more individual or involve a small group. Examples of passive recreation include such items as a walking trail, individual picnic sites, nature appreciation, and birding.

Many parks include both active and passive recreation; although the degree of each type of recreation will vary with the park type. For example, a community park emphasizes active recreation while a regional park may emphasize passive recreation but contain some areas for active uses such

as water skiing or camping. Natural areas, commonly thought of as open space, tend to only accommodate passive recreation.

Recreation Offered by the County

Parks. County Parks provides numerous types of recreation. Just as the County provides many types of parks, it attempts to provide recreation consistent with the park type. At the County's mini and neighborhood parks, recreation typically consists of items such as children's play equipment, individual picnic areas, open play areas (for Frisbee or throwing a baseball), and perhaps benches for reading or viewing nature.

The County's community parks tend to provide items such as sports complexes, community centers, tennis and basketball courts, skate parks, group picnic areas, and perhaps a swimming pool. Recreational activities at the County's regional parks include items such as camping, fishing, multi-use trails (for equestrians, hikers and bicycles), boating, golf, and in some cases, water skiing and wind sailing.

The County's major camping, fishing and boating facilities are located at Santa Margarita Lake Regional Park and Lopez Lake Recreation Area. Although both parks are in rural settings, Santa Margarita Lake has a more rustic feeling. This park provides scenic views, an extensive trail system, limited camping, and a peaceful setting. Lopez Lake offers over 300 campsites, many with hook-ups. Lopez also provides the County's only water park, Mustang Water Slides, as well as an ideal location for water skiing and windsurfing.

Recreation Programming. Offering of league play or classes (soccer camps, league sports, etc.) has not historically been provided by County Parks. The main exception is the area of aquatics. The County offers swim lessons and aquatic programs such as junior life guarding and aqua aerobics during the summer season.

Golf Courses. In addition to neighborhood, community and regional parks, County Parks also operates three golf courses: Morro Bay (photo), Chalk Mountain, and Dairy Creek. All are 18-hole, championship style facilities. Chalk Mountain Golf Course is a part of Heilmann Park in Atascadero, Dairy Creek Golf Course is a part of El Chorro Park near the City of San Luis Obispo, and Morro Bay Golf Course is located within Morro Bay State Park



Morro Bay Golf Course - As seagulls see it

Trails. County Parks offers trails within its regional parks, to a lesser extent, within community parks, and in some areas as community or neighborhood connectors. Trails connecting communities and special features are another key part of the County's trail system. These include the Bob Jones Pathway which will eventually connect Avila Beach with the City of San Luis Obispo and the Hi Mountain Trail, intended to connect Lopez Lake Recreation Area with the National Forest. Other trails currently under development will provide passive recreation while connecting parks, schools, libraries with neighborhoods. Most trails in the County are designated for multi-use, allowing equestrians, pedestrians and bicycles.⁸

Several large trails will connect numerous communities in the County. The Juan Bautista de Anza National Historic Trail travels across our county and represents an important recreation activity and a link to our California past. This national trail commemorates the route followed by a Spanish commander, Juan Bautista de Anza, in 1775-76 when he led a contingent of 30 soldiers and their families to found a presidio and mission on the San Francisco Bay. Other major trails in the County include the Salinas River and the California Coastal Trail.

In addition to the trails proposed in this Element, the County Public Works Department administers the County's Bikeways Plan. The Bikeways Plan indicates proposed Class I, II and III bicycle paths throughout San Luis Obispo County. The two documents compliment one another.

Special Places. County Parks also provides a variety of special recreational opportunities. These include access along and to the coastline; historic sites such as the Rios Caledonia Adobe; and natural areas which balance passive use with resource preservation.

Partnerships. Many groups are willing to bring substantial resources, especially volunteer help, expertise, and grantsmanship, to projects that would benefit our County Parks system. The San Luis Obispo Botanical Garden is an excellent example of a partnership between County Parks and a non-profit organization with a related mission.

Recreation Offered by Our Cities

San Luis Obispo County's seven incorporated cities operate their own parks and recreation programming. Typically, city parks and their recreation programs are available to people who live within the unincorporated areas just as county parks are available to city residents. A variety of partnerships between County Parks and cities have expanded recreation opportunities for use by local residents regardless of whether they live within a city or the unincorporated part of the county. Examples include co-development of Barney Schwartz Park in the City of Paso Robles and the joint use of ball fields between the City of San Luis Obispo and the County.



Trail at El Chorro Regional Park

⁸ Private property owners have liability protection from the California Recreational Use Statute (excerpted in Appendix A). This protects a property owner when a person enters their land for a variety of recreational purposes.

Private Recreation

Many recreation opportunities are offered by private enterprise. Swimming pools, gyms, yoga centers, bowling alleys...a wide variety of important recreation opportunities. Larger, privately developed facilities may include off highway vehicle parks. These should be taken into account in any parks planning activity.

How Recreation Need is Determined

The demand for certain types of recreation ebbs and flows over time and popular new recreational pursuits can create acute unmet demand in a short period. For this reason, some traditional models for what needs to be in every park needs to be periodically reexamined. For example, 30 years ago, most small communities had perhaps one organized youth sport~Little League Baseball. Today, soccer has generally reached or exceeded the level of participation in Little League, and other activities such as skateboarding, adult softball and soccer have proliferated.

Given the typically long planning timeframe leading to park or facility construction, this Element recognizes a need for recreational facility planning to be flexible, adaptive and responsive to evolving needs. Determining those needs is best accomplished by:

- Examining statewide and national trends
- Performing periodic county-wide surveys
- Conducting local workshops, and
- Preparing and updating master plans for each park facility

How Recreation is Provided

The process of providing recreational facilities and services is fundamentally three-fold: 1) assessing need, 2) assessing available resource, and 3) setting priorities.

Assessing Needs. As noted above, needs assessment is an ongoing process which involves community input and periodic review. Community input and research provide a sound basis for a master plan which documents both short and long term goals for a facility. Although frozen in time, a master plan provides a predictable tool for achieving community needs.

The California Coastal Trail (CCT), officially designated by state legislation, could stretch 1300 miles along the entire California coast. Completion of the CCT in San Luis Obispo County will be a collaborative effort between County Parks, the Coastal Conservancy, the Coastal Commission, and Coastwalk.



Fishing is good in Santa Margarita Lake

Assessing Resources. This includes two major factors: 1) the capital costs to acquire and develop facilities, and 2) the cost of ongoing maintenance once facilities are constructed. Capital costs are a one time expense but they are far overshadowed by the cost of staffing and maintaining facilities. The ability to sustain a viable park system must be considered prior to committing any capital funds to construct new amenities. Thus, community need must be balanced with available financial resources.

Setting Priorities. Once we know what to build and have identified a funding source, we must determine the order in which we will undertake new projects. An objective, fair system for determining priority is necessary to avoid undue conflict between special interest groups. Such a system is outlined in Chapter 5, Choosing Parks and Recreation. Chapter 8 Parks and Recreation Project List provides a list of proposed recreation and park facilities.

Recreation Goal, Objectives and Policies

GOAL #2: Recreation that serves the County's residents and visitors, various age groups, varying economic situations and physical abilities.

GENERAL RECREATION:

OBJECTIVE B: Provide new and expanded recreation within the County consistent with Chapter 8 Parks and Recreation Project List, and the County's available funding.

POLICIES:

- 3.1 To provide an equitable distribution of recreation throughout the County, County Parks should attempt to provide new or expanded recreation (as a first priority) in those Planning Areas that have:
 1. Experienced faster growth rates.
 2. Very limited existing park acreage and/or recreation opportunities in relation to population density. When assessing existing park acreage and/or recreation opportunities consider parks and recreation offered by all entities provided that entity offers comparable service to the County's unincorporated population.
- 3.2 Provide recreation at the County's parks consistent with community needs.
- 3.3 Seek joint use agreements, volunteer and other partnership opportunities to augment recreational services and reduce project costs.
- 3.4 When considering the acceptance or development of capital intensive recreational facilities such as community centers, indoor sports centers, and aquatic centers, attempt to get numerous entities involved to split the cost of acquisition, design, development, and maintenance.
- 3.5 Provide recreation programs at the County's owned or leased facilities which provide adequate cost recovery.
- 3.6 Recognize that many legitimate recreation activities are possible even through they may not be provided by the County. From bowling alleys to off-road vehicle courses, private enterprise offers a greater potential to supply various recreation needs. The County will work to assist private enterprise in providing these activities while at the same time it will work to ensure that they are appropriately located so as not to necessarily impact the environment or negatively burden surrounding land uses.

TRAILS:

OBJECTIVE C: Provide a viable multi-use trail system which is protective of private property interests and public resources, and consistent with Chapter 8 Parks and Recreation Project List.

POLICIES:

- 3.7 County Parks shall consider as the highest priority those trail projects which:
1. Are on land owned or operated by the County, including public rights of way.
 2. Connect urban communities or provide access to recreation areas.
 3. Complete a trail corridor, where only small portions are missing.
 4. Will be popular due to their length or location.
 5. Offer alternative transportation.
 6. Solve a safety concern.
 7. Include a funding source.
 8. Minimize costs of development and maintenance.
- 3.8 To protect the interests of adjacent land uses (both public and private) and the environment, trail projects shall:
1. Be consistent with the standards in the General Plan including the County's Agriculture and Open Space Element.
 2. Stay as far away as reasonable from production agriculture,⁹ commercial activities and residences.
 3. Be built to minimize impacts to sensitive resources.
 4. Provide signs that identify permitted trail uses; directions to relevant public areas; and, provide for safety and protection of trail users and adjacent private property.
 5. Provide trail fencing where necessary to discourage trespass onto neighboring land and to protect sensitive resources.
 6. Impose enforceable limitations on the trail use, as appropriate.
 7. Be designed and constructed consistent with the trails standards contained in Appendix B of this document.

⁹ Production agriculture is defined in Appendix J of the Agriculture and Open Space Element, and determined by the County Agriculture Commissioner.

- 3.9 County agencies will work together to coordinate the development, maintenance and use of trails.
- 3.10 Extensive trail systems, such as the California Coastal Trail, the Juan Bautista de Anza and the Salinas River Trails, will generally be developed in a series of shorter, but viable, segments. Such segments shall not be constructed until a viable link can be established connecting residential communities, parks, staging areas, or other public points of interest.
- 3.11 Eminent domain will not be used for trail establishment.
- 3.12 Where public lands are not available or adequate to accommodate a public trail, a trail dedication in easement or fee across private property shall be considered and may be obtained only in the following instances:
1. From a willing seller or donor.
 2. As part of a New Town or Specific Plan that would create urban uses.
 3. As a condition of a project approval, subject also to Policy 3.13:
 - a. For land designated Agriculture when:
 - i. a general plan amendment would change the land use category from Agriculture to another land use category; or
 - ii. a discretionary project that would convert agricultural land to uses¹⁰ not related to agriculture; or
 - iii. a cluster subdivision would create eight or more residential parcels.
 - b. For land not designated Agriculture, but in production agriculture, when a discretionary project including a subdivision would convert land to uses¹¹ not related to production agriculture as determined by the County Agricultural Commissioner's Office.
 - c. For all other land not excluded under (a) and (b) above, for any discretionary project (parcel map, tract map, development plan, minor use permit, conditional use permit, etc.)

¹⁰These uses are limited to: religious facilities, libraries or museums, schools, commercial electric generating plants for the generation or distribution of electrical energy for sale, manufacturing, recycling facilities (excluding composting), residential care facilities, public safety facilities, commercial retail facilities (excluding restaurants and roadside stands), and waste disposal sites. These are defined in Titles 22 and 23 of the San Luis Obispo County Code.

¹¹ *ibid.*

- 3.13 When a trail dedication is required as a condition of a discretionary permit, the required trail dedication must:
1. Be proportional to the level of development being proposed;
 2. Have an appropriate nexus to the effects of the permit;
 3. Be shown on an adopted plan or be a New Town or Specific Plan development as noted in Policy 3.12 (2) above;
 4. Result in no long term, unmitigable environmental impacts; and
 5. Comply with all applicable local, state and federal laws and regulations.
- 3.14 Prior to the construction and/or County acceptance of a public trail corridor, the approving authority must make findings that:
1. Sufficient funds are available for the trail's on-going maintenance; and
 2. The liability for the trail has been addressed pursuant to Policy 3.15.
- 3.15 The County shall fully indemnify, protect and hold harmless (including all costs and attorney fees) private property owners who dedicate or grant a public trail easement from, and against, those risks and damages that arise out of the usage of the trail easement by the public and which, in good conscience, should not be borne by the private property owner.
- 3.16 The County shall assure that if a public trail easement is abandoned, or if the liability acceptance is discontinued, the trail easement shall revert to the underlying property owner(s).

GOLF:

OBJECTIVE D: Provide a quality and affordable golf program at the County's golf courses.

POLICIES:

- 3.17 The County's golf courses should continue to be operated as an enterprise fund.
- 3.18 Each County golf course should have a master plan. New development at an individual golf course should be consistent with the project's master plan.

- 3.19 Land for new County operated golf courses should only be obtained and developed after completing a funding plan. The funding plan should assess various components including such items as the amount of existing rounds in the County (public and private), the amount of anticipated future rounds (public and private), and what populations the new course would serve.
- 3.20 Develop recreation facilities or opportunities (such as trail corridors) along the perimeter or interior routes of the County owned or operated golf courses where such corridors will not adversely impact golfers or jeopardize user safety.
- 3.21 Continue to use environmentally sensitive maintenance techniques at the County's golf courses.

CHAPTER 4: SPECIAL PLACES AND USES

Tomorrow to fresh woods, and pastures new.

Milton

Special Places

San Luis Obispo is blessed with a variety of special places, such as the Rios Caledonia Adobe, the Elfin Forest, and the monarch butterfly preserve in Monarch Grove. These places are unique assets in the County that can enrich the lives of residents, protect sensitive natural resources, and draw visitors to the county. Historic, coastal and special natural features are finite. They provide a fundamental reference to what our area is, what it has been,

and what it can be for our children.



Elfin Forest Boardwalk in Los Osos

Types of Special Places

Because of their variety, Special Places are difficult to categorize neatly, however we have broadly categorized them as:

- Historic Facilities,
- Coastal Access, and
- Natural Areas.

We cannot always predict when or where Special Places may become available. Nevertheless, we should approach these like any other recreational resource, with an appreciation for community needs, value of the resource, and the long-term responsibility and maintenance associated with the facility.

Special Places and Facilities

Historic Facilities. Historic Facilities in the County include everything from outstanding examples of the Spanish architectural style in early California adobes, to sites that reflect the Chumash lifestyle, to the first generation of ranchers in the early 1800's, to the entrepreneurs of the early 1900's. The size of these facilities depends on the particular structure or site being managed (there are no NRPA standards for historic park acreage). Existing parks may contain remnants of these historic places. One example of a County managed Historic Facility is the Rios Caledonia Adobe in San Miguel.

Coastal Access. Coastal Access provides public access to and along California's coastline, including the Morro Bay Estuary. Access ways are defined as vertical and lateral. Vertical access connects the closest public road to the coast, in some cases simply by providing a viewing platform. Lateral access provides access along the coastline, basically providing an area to walk along the beach. The County currently maintains over 25 vertical access ways and much of San Luis Obispo County's coastline has been preserved for lateral access by local, state and federal agencies. The County's various coastal Area Plans and the Local Coastal Plan (as adopted by the State) will serve to guide development and the provision of future Coastal Access, including the County's participation in the development of the statewide California Coastal Trail.

Natural Areas. Monarch butterfly habitat, the Salinas River corridor, and oak woodlands are but a few types of Natural Areas identified for protection in our county. Bishop Peak and the Elfin Forest are two examples of Natural Areas maintained by County Parks. While the preservation of these areas is addressed in the County Agriculture and Open Space Element, they are also part of our recreational resources, and therefore are recognized as such in this Element. Furthermore, the ultimate responsibility for the acquisition, preservation and maintenance of these sites rests with County Parks.



Windmill and oak trees

Special Places Goal, Objectives, and Policies

GOAL #3: Maintain and augment access to and along the coast.

OBJECTIVE E: Provide a viable coastal access program through the County's coastal Area Plans and the Local Coastal Program.

POLICIES:

4.1 Continue to provide and maintain viewing areas, viewing platforms, vertical access, and lateral access along the County's beaches consistent with the County's coastal Area Plans and Local Coastal Program. Use joint use opportunities and adopt-an-access programs as they are available.

GOAL #4: Natural areas preserved within the County that protect unique and sensitive resources.

OBJECTIVE F: Provide natural areas consistent with Chapter 8 Parks and Recreation Project List, and/or the County's Agriculture and Open Space Element.

POLICIES:

4.2 When acquiring a natural area or considering the acceptance of a donation give first priority to sites that meet a majority of the following criteria:

1. Provide significant or locally important resource protection.
2. Would add important acreage to an existing County park or natural area.
3. Would allow for meaningful passive recreation, nature appreciation, and public education.
4. Would be better managed by the County than another entity due to its location or other factors. For small areas within a private subdivision, a homeowners association or similar entity should own and maintain areas set aside as mitigation.
5. Include a reasonable endowment fund or other funding mechanism/approaches for maintenance.
6. The site can be adequately protected and restored by the County or another organization or partnership.

In general, projects that do not meet these criteria should receive a low priority or not be accepted by the County.

4.3 When addressing changes in natural areas:

1. Be consistent with an approved master plan. Within the master plan include items such as environmental education, passive recreation, and methods for resource protection and restoration.
2. Provide adequate buffers between the natural area and adjacent urban or rural uses.
3. Seek joint use opportunities and adopt-a-natural area programs as they are available.

CHAPTER 5: CHOOSING PARKS AND RECREATION

Look a gift horse in the mouth, but discreetly.

Decision Process

All too often parks and recreation planning is set aside when an opportunity for land or equipment is presented to public officials. Sometimes these opportunities coincide with stated goals, and other times they run counter to them. This Element proposes to reduce the randomness of park and recreation acquisition, and instead provide a template for decision-making when these opportunities do arise.

This chapter also attempts to define a delicate balance between benefactors and public benefits. A large portion of our recreation inventory was given to us through the kindness of individuals who were blessed with this bounty. Many are loath to question the wisdom of accepting land into our County inventory. Yet staff must often point out that the initial capital investment in a property is the smallest component of its ultimate cost. Park facility development and especially long term maintenance will far outstrip what it would have cost to purchase the land in the first place.



Old barn at Lopez Lake

What follows is a process for choosing park and recreation facilities. This is designed to make certain that our decisions are based upon an understanding of our current resources, demographics, input from those most affected, and our long-term goals. Hopefully, all proposals will be treated uniformly, fairly and responsibly, with all parties having a clear understanding of the process. This will help ensure that no one feels slighted, even if the project is not implemented. This will also ensure that information is well distributed and the effort is coordinated amongst the appropriate parties.

Parks and Recreation Commission

The Parks and Recreation Commission (PRC) advises the Board of Supervisors and the Parks Division of the Department of General Services in the policy, planning and development of the County's park system, including implementation of this Element. The PRC is made up of five members who are appointed by the Board of Supervisors and represent each of the five supervisorial districts in the County.

Decision Tree

Once each year, prior to completion of the Parks budget, the Parks Division Manager will provide the Parks and Recreation Commission an update on the status of existing and any proposed significant new Capital Improvement Projects (CIP), which will be derived from the list in Chapter 8. Whenever an individual, public official or group want significant¹² new recreation resources or changes in use, or a benefactor proposes a gift, or a property of interest comes on the market the Parks Manager or his/her designee will:

1. Meet with the project proponents to better understand the proposed project.
2. Perform a preliminary written analysis (staff report) for the proposed project. The staff report should include:
 - a. An assessment of the project's consistency with stated goals, priorities, and County plans, policies and programs. Inconsistency may terminate the project's review.
 - b. Rating of the project per the Capital Improvement Rating Criteria.
 - c. A projection of anticipated capital costs (acquisition, development, etc.) based on similar facilities within the County or elsewhere and the potential source(s) to cover these costs.
 - d. An assessment the potential maintenance costs based on similar facilities within the County or elsewhere and the potential source(s) to cover these costs. This analysis should include current and future staff required to maintain the proposed facility.
 - e. An analysis of project attributes including the community that will benefit (the stakeholders), special needs served, and other attributes of the proposed project.
 - f. An assessment of whether there will be other project issues, such as a difficulty obtaining permits due to environmental issues, hazards onsite, compatibility with adjacent land uses etc.
 - g. An assessment of whether there are alternatives to the proposed project that may be more consistent with County plans, policies or goals, funding availability, etc.
 - h. Other items that should be considered.
 - i. A recommendation regarding the proposed project based on the items noted above and any others deemed important by the Parks Manager.
3. Schedule the project for a Commission meeting once the information noted in



Bob Jones Bike Trail

¹² Significant can be defined as a Capital Improvement Project (typically at least \$25,000) as provided for in the Division's 5-year Capital Improvement Plan. Smaller projects would be dealt with administratively, unless the Manager believed it merits the attention of the PRC.

1 and 2 above has been completed. Notice project stakeholders, members of the general public, and other likely interested persons when the Commission will be reviewing the proposed CIP list. Based on Commission review, determine priority projects for each fiscal year.

4. If members of the public or the project initiator are dissatisfied with the Commission's determination, the project priorities may be determined by the Board of Supervisors through the budget process.

Choosing Parks and Recreation Goal, Objective, and Policies

GOAL #5: An equitable and realistic park, recreation, natural area, and coastal access project list.

OBJECTIVE G: Determine a reasonable list of priority projects based on community needs, staffing, practical consideration of projects development potential, and funding.

POLICIES:

- 5.1 Project priorities should be determined by the County's rating criteria [Appendix D] and decision tree, and balancing staffing with community needs and funding.
- 5.2 When a County department provides or updates elements or other local plans (such as a design plan or bicycle plan), proposed projects (such as trails and parks, or road abandonment) should be referred to Parks Division and brought to the Parks and Recreation Commission for review and input before the document is taken to the County's Planning Commission or Board of Supervisors for review and approval.
- 5.3 Examine national and statewide trends then conduct countywide surveys every five to seven years to determine user needs and ascertain customer satisfaction. These surveys can help determine priority projects.
- 5.4 Projects the Parks and Recreation Commission determines as priorities should be indicated in the 5-year Capital Improvement Program as a means of coordinating the acquisition, improvement, and rehabilitation of County park facilities.
- 5.5 The Parks and Recreation Commission may make minor additions to the Project List (Chapter 8), with the understanding that the ultimate approval and funding for a project resides with the Board of Supervisors. Deletions from the Project List can only be made by the Board of Supervisors.

CHAPTER 6: FUNDING & MAINTENANCE

Long grass sways
I am charmed
A hidden rock
Twists my foot
Kuraku

Introduction

By fiscal year 2005-06, the combined cost to maintain the County Parks Program was more than \$8.6 million. This consists of two primary components: the Golf Program at \$2.7 million and the Parks Program at nearly \$6 million.

The **Golf Program** operates as an enterprise fund. The County's three golf courses¹³ are financed entirely by golf user fees, with no direct impact on the rest of the park system or the County's general fund. In other words, no tax dollars are earmarked to fund the golf program.

The **Park Program**¹⁴ depends on a combination of funding sources. As is typical with most local park programs, the County's parks facilities are not able to support themselves entirely with user fees.

This Element focuses upgrading and expanding the County's parks system. Because the Golf Program is able to generate its own funding, this chapter will focus on funding the Parks Program. This funding is important since over time, implementation of this Element may require the significant addition of new parkland as well as the development of new recreation facilities such as tennis courts, community centers and trails.

In order for the County to expand the current park and recreation system, adequate and dependable funding sources will be needed. These funding sources must equally address acquisition, development and maintenance costs. This chapter identifies the existing funding sources for the County Parks Program and considers options for future funding. In this way, decision makers and the public can better ascertain what lies ahead.



Park Maintenance



Morro Bay Golf Course

¹³ Chalk Mountain GC, Dairy Creek GC and Morro Bay GC

¹⁴ Including parks, trails, special places, and the facilities and programming associated with them.

Funding Acquisition and Development

The development of parks, recreation facilities and natural areas within County Parks has been funded by a variety of sources including:

Grant funding. Grants have provided this County with significant capital funding many several years. Many grants have been used to design and build new trail corridors and/or expand existing trail corridors, such as the Bishop Peak Trail, the Elfin Forest Boardwalk and the Bob Jones Pathway. Grant funds have also been used to acquire natural areas (such as 1,280 acres of former federal land adjacent to Santa Margarita Lake Regional Park) and upgrade facilities at existing parks. California park bonds have been significant sources of capital project funding in this county and throughout the state.

Development impact fees. These fees have been the major funding source for new or expanded neighborhood and community parks. In the early 2000s, the County collected roughly \$2 million annually in park development impact fees¹⁵. Since impact fees are assessed on new development, this source of revenue generation fluctuates with the rate of residential growth. Development impact fees have made possible the replacement and expansion of playgrounds and restrooms at community parks throughout the County.

Developer contributions. This is another source of new recreational facilities. Conditions placed on new subdivisions and other new development has resulted in some new parkland, new coastal access, and the creation of various trail segments. Developer conditions have been a major factor in creating numerous trail segments in areas such as Nipomo and Templeton and natural areas such as Monarch Grove in Los Osos.

Joint use agreements. Agreements with other public agencies have provided new recreational facilities through the sharing of development and maintenance expenses. Partnerships with the San Luis Coastal and the Lucia Mar School Districts have produced playgrounds and soccer fields available for both school use and the general public. Cooperative funding with cities and community services districts has also provided new park areas and recreation facilities for County residents. In most cases, the County provided funds toward acquisition or development while the other agency funded the facilities' long-term maintenance.

SLO County's Parks Program currently uses the following funding sources for **acquisition and development**:

- Grants
- Development Impact Fees
- Developer Contributions
- Joint Use Agreements
- Donations/Volunteer Assistance

¹⁵ Development Impact Fees are intended to provide new facilities that offset the impact of new residential development on existing service levels. These fees are assessed on new residential development only. Quimby and Public Facility Fees can only be used for expanding or upgrading neighborhood and community recreation facilities.

Donations. Gifts are an important source of park acquisition. Historically, donations of parkland have been an effective tool for individuals and organizations to give a lasting gift to the community. Examples in San Luis Obispo County range from the gift of Templeton Park in 1913 to the donations of Liz Duveneck Park and Jack Ready Park in the early 2000's.

Volunteer Assistance and Collaborative Agreements.

Assistance provided directly by community groups and the general public can also generate new park and recreation facilities. Such collaborative agreements have long been an important strategy for developing needed facilities beyond the immediate ability of County funding. Examples of these collaborative agreements include the botanical gardens have been developed at El Chorro Regional Park and Nipomo Community Park with the San Luis Obispo Botanical Garden and the Nipomo Native Garden, respectively. The Cambria Rotary Club constructed the bandstand at Shamel Park. Volunteer assistance and collaborative agreements can continue to play a role in developing capital assets and should be pursued throughout the county.



Play equipment at a neighborhood park

Funding Maintenance

The County Parks Program is charged with providing a range of public park "and recreation services. Providing those services requires staff, materials and equipment. As of 2006, thirty park rangers are employed to conduct the day-to-day maintenance of the County's roughly 14,000-acre parks system. That includes duties such as mowing lawns, pruning trees and cleaning restrooms. In addition to these and the thousand other jobs required to keep parks healthy and safe, daily maintenance costs includes funding basic housekeeping supplies and equipment needed to clean facilities, maintain landscaping, etc. Other daily expenses include funding utilities for security lighting, hot showers for campgrounds, trash disposal, and much more.

The maintenance of parks, recreation facilities and natural areas within County Parks has been funded by a variety of sources including:

User Fees. These fees currently fund less than half of the Parks Program's maintenance expenses. Charges for camping, boating and reserving group picnic areas are typical of park User Fees. Unfortunately, they will never fully offset the costs of providing the countywide Parks Program. While camping and boating fees can fund a single site operation like Lopez Lake, many of the services and facilities provided throughout the County are free and/or heavily subsidized. For example, the County's six swimming pools only recoup about 25% of their operating costs through User Fees.

- SLO County's Parks Program currently uses the following funding sources for **maintenance**:
- User Fees
 - General Fund
 - Grant funds (major maintenance)
 - Donations/Volunteer Assistance

General Fund. The General Fund currently contributes approximately half of the maintenance cost of the Parks Program, supplementing User Fees. The General Fund is the primary funding source for most County services, including such diverse programs as law enforcement, libraries and public health. The competition for General Fund monies limits the potential for further support of the Parks Programs.

Grant Funds. California State Park Bond Acts has provided grants to counties, cities and special park districts that can be used for major maintenance projects. While such funds may not be used for daily maintenance needs, like mowing lawns and cleaning restrooms, they can provide funds for overdue major maintenance. Major maintenance projects such as paving deteriorated parking lots and renovating old restrooms can help to reduce daily maintenance expenses simply by improving the condition of park facilities. The availability of grants and bond funding is variable and often subject to the vigor of the general economy.

Donations, Volunteer Assistance and Collaborative Agreements. These play a key role in supplementing the efforts of Parks staff and can add valuable services and park improvements. Donations have helped to finance trees and benches at parks and natural areas, tennis courts at Los Osos Community Park, sand wheelchairs for public beaches, and free recreational swimming at County pools. Groups such as Small Wilderness Area Protection, the Friends of the Adobes, and the San Luis Obispo Botanical Garden have provided countless hours of routine maintenance and visitor service programming at sites throughout the county. By the early 2000s, County Parks annual volunteer service was already exceeding 50,000 hours of community support and with more effort by staff, more volunteerism is possible. Volunteers help to develop trails, landscape park property, serve on advisory committees/commissions, develop and maintain dog parks, and much more. This program also provides a direct benefit to groups and individuals seeking opportunities to serve their neighbors and give something back to the community. Just as important, without donations and volunteer assistance, County Parks could not sustain its current level of service.

The Problem

County Parks faces two distinct funding challenges. The first is the high cost of funding new facilities. The second is funding ongoing maintenance of existing and new facilities. This Element is filled with programs and projects that are intended to provide a healthy, balanced community now and in the years to come. However, providing those new projects without addressing their ongoing maintenance costs is shortsighted. Most people would agree that it is impractical to build and develop new recreational resources without the ability to sustain them.



Young runners participate in the triathlon

Funding New Facilities. Although in good years County Parks has accumulated annual revenues of roughly \$3 million (in 2003 dollars) from grants and impact fees, due to the County's high property values this does not buy much. And this still leaves the issues of how the maintenance of new parks would be addressed, or what upgrades at existing parks would need to be postponed in order to provide new facilities.

Funding Maintenance. With user fees unable to fully fund park facilities and inflation eating into the General Fund contribution, the result has been the deferral of major maintenance projects and a general decline in facility infrastructure. When the cost of maintaining existing facilities exceeds available funding, determining maintenance priorities can be difficult. Deferring maintenance during such times generally results in greater future costs to rehabilitate neglected parks. In the mean time, the financial exposure to liability and safety issues may outweigh any short-term savings.

Solutions

As with much of life, the Parks Program is faced with two basic options: (1) maintaining the *status quo* or (2) seeking change to keep up with a changing environment.

Option One: More of the same, only less of it. Without providing adequate maintenance funding, it is impractical to add any new recreational facilities that cannot generate their own source of revenue. Such a strategy will limit future recreational development to facilities such as golf courses, campgrounds and a limited range of other facilities for which user fees can be charged to cover operating costs.

Under this scenario, items which do not have an identified revenue source for maintenance would have a very low development priority. Thus, facilities such as new neighborhood or community parks, trails and Special Places would be low priority projects. Items such as regional parks and golf courses, which generate user fees to fund maintenance costs, would be a higher priority and likely the only facilities developed. Exceptions would be facilities created with an endowment fund or some other type of special revenue that covers maintenance.

The benefit of this approach is regional parks serve local residents as well as a tourist population. Providing additional regional parks could provide an economic benefit to the County. The downside to this approach is unless local communities incorporate and/or assume responsibility for local parks, that urban area would likely be deficient of these services. Also, if land is not set aside when it is still available, opportunities for future parks when the community incorporates may be limited.



Going down the big slide

Option Two: Grow smart for a healthy community. Funding sources for growing and maintaining a Parks program integrated into the community are numerous. Different counties use different models based on the unique character of the local community and its own blend of funding sources.

Chapter 2 cites the health, social and economic benefits provided by a balanced Parks Program. To achieve this result additional funding options will need to be pursued. Some of these funding options are identified in Appendix C. Under Option Two, the County would hire a consultant to put together a funding program for the parks system that balances community needs with revenues. This analysis could identify funding sources such as additional user fees, other taxes that could be shared with the Parks Program, and even the costs and benefits associated with developing a Parks District. Because Option One would not appear to be consistent with community needs or desires, this Element is recommending that Option Two be explored.

Funding Acquisition, Development & Maintenance Goals, Objectives, and Policies

GOAL #6: A variety of funding sources to expand, acquire, develop, and maintain the County's parks, recreation opportunities and natural areas.

OBJECTIVE H: Develop a funding mechanism that provides for acquisition, development and maintenance of parks, recreation, natural areas, and coastal access, taking advantage of collaborative agreements and volunteers.

POLICIES:

- 6.1 List projects in the County's Capital Improvement Program.
- 6.2 Develop a funding program that balances community need with available revenues. Use an economic consultant to review existing costs and provide recommendations for a viable funding program. This program should consider the formation of a parks district.
- 6.3 The County should enact and maintain an ordinance pursuant to the Quimby Act that will require a dedication of land and/or payment of fees in lieu thereof, for park and recreational purposes as a condition to the approval of a tentative tract or parcel map for residential subdivisions.

MAINTENANCE

GOAL #7: High quality park maintenance that is cost effective and environmentally sensitive.

OBJECTIVE I: Provide new or expanded public facilities consistent with available maintenance funding.

POLICIES:

- 6.4 Prior to accepting or developing a new park, County Parks shall determine the long-term maintenance and operating costs associated with the proposed project. The County shall not develop the park until adequate funds are available for maintenance.
- 6.5 Ensure that County parks receive a net benefit to the County park and recreation system when a park or recreation facility is impacted by private or quasi-public infrastructure and other easements.

- 6.6 Require new development adjacent to parks, recreation and natural areas to be designed to function with and enhance park resources. Adjacent, new private development should not detract from or use adjacent park or natural area resources for their own private use.
- 6.7 Conduct project maintenance consistent with a facility's master plan.
- 6.8 When maintaining park, recreation and natural area facilities attempt to minimize signs and other structures that may impact the aesthetics of the facility.
- 6.9 County Parks should not undertake maintenance responsibilities better handled by another body. For example, facilities within private development (such as mini-parks, basin parks, mitigation areas, open space, and short segments of trails) shall be maintained by a homeowner's association or a similar entity.
- 6.10 If County maintenance funding is inadequate to provide all park types, concentrate new park acquisition on regional park lands since these parks serve the largest number of users and are the least costly for the County to maintain.
- 6.11 Use methods within County Parks` facilities that reduce maintenance costs, such as the use of drought tolerant landscaping, solar oriented structures, structures with natural lighting during daylight hours, and stainless steel fixtures which have a longer lifetime and are more resilient to vandalism.
- 6.12 Continue to assess ways of providing additional maintenance funding including:
1. The periodic review of user fees.
 2. Ways to cut staff time.
 3. Additional ways to manage and use volunteers.
 4. Assessing options such as the formation of a parks district.

CHAPTER 7: DEFINITIONS

Active Recreation. Active recreation tends to involve facilities and usually larger groups of people. Some examples of active recreation include items such as community centers, skate parks, tennis courts, sports facilities, and swimming pools. (See also **Passive Recreation**).

Coastal Access. Coastal Access provides public access to and along California's coastline, including the Morro Bay Estuary. Accessways are defined as vertical and lateral. Vertical access connects the closest public road to the coast, in some cases simply by providing a viewing platform. Lateral access provides access along the coastline, basically providing an area to walk along the beach. A viewing platform provides visual access to the coast.

Community or Recreation Center. A public building used for indoor recreation, community activities, and/or public events. Common indoor recreation activities within a community center include a gymnasium, game area, and stage. Typical public areas include rooms for craft or fitness classes, meetings rooms, and areas for social or cultural gatherings. Community centers may also offer recreation programming.



Castilleja densiflora

Community Parks. Community parks are roughly between 20 and 25 acres and provide recreation facilities that serve not only the local community but also, in some cases, visitors from outside the city or county. For example, a community park, which includes numerous sports fields, will draw people from outside the community for tournament play. Typical facilities might include a skate park, sports fields (football, baseball, soccer, and softball), a swimming pool, a sufficient number of tennis courts for tournament play, group picnic areas, and/or a community center. Although community parks tend to be more active in nature and/or provide a greater mix of active recreation, they may also contain some passive uses such as trails, scenic overlooks, benches and nature appreciation.

Enterprise Fund. Enterprise funds are established to finance and account for the operation and maintenance of facilities and services which are self-supporting by user charges with the use of tax revenues.

General Fund. The General Fund is the main operating fund of the County accounting for expenditures and revenues for countywide activities.

General Fund Support. General Fund Support is the amount of General Fund financial support to a given budget unit after revenues and other funding are subtracted from expenditures.

Goals. Goals are a general expression of community values, an ideal future result or condition related to the mission statement.

Impact Fees. In San Luis Obispo County, Impact Fees includes Quimby fees and Public Facility Fees. These fees are assessed on new residential development. Quimby fees are collected when new residential lots are created, and can only be used to expand, acquire, rehabilitate, or develop community-serving parks. Public Facility Fees are collected upon construction of a new residential unit, and these fees can only be used to expand, acquire, or develop community-serving parks.

Linear Parks. Linear parks are located along a corridor such as a river, creek, or a trail system. These parks tend to be narrow and long in configuration. Linear parks may link schools, parks or neighborhoods and may also serve a community's transportation needs. Often a linear park derives its shape by conforming to an edge: of the coast, of a river or creek or an abandoned railroad right of way.

Master Plan. A document guiding the development of a park, natural area, recreation site or regional trail. This document provides maps and text describing existing natural resources as well as the future location of proposed recreation, natural areas, and infrastructure. The preparation of the master plan includes input from the public as well as relevant federal, state and local agencies.

Mini-Parks. Also known as **Pocket Parks**, mini-parks are the smallest type of park. They may range in size from a small residential lot, in some cases as small as 6,000 square feet, up to 5 acres. In most cases, mini-parks are usually one acre or less. Because of their small size, mini-parks may be more passive in nature. Mini-parks serve a distinct neighborhood.

Mission Statement. A Mission Statement is a broad statement which defines the agency's values, principles, and what matters most. Goals and policies should be guided by an agency's Mission Statement.

Natural Area Preserve. An area of land or water managed by County Parks, a similar public agency, or a private non-profit which remains in a predominantly natural or undeveloped state to provide resource protection and passive recreation for present and future generations.

Neighborhood Parks. Neighborhood parks typically serve nearby populations consisting of one or more neighborhoods. According to National Recreation and Parks Association standards, a neighborhood park may range in size from roughly five to ten acres. In general, neighborhood parks are within walking distance from the people they are primarily intended to serve, i.e. one mile or less. Neighborhood parks usually include passive recreation as well as some active recreation. Typical facilities might include children's play equipment, a



Children playing at Hardie Park in Cayucos

court game (such as basketball, tennis or handball), a turf area and individual picnic areas.

Objectives. Objectives are measurable statements related to and reinforcing the goals of the Element.

Open Space. Any parcel or area of land or water which is essentially unimproved and devoted to an open-space use as designated on a local open space plan as open space for the preservation of natural resources, the managed production of resources, for outdoor recreation, or for public health and safety (see Government Code Section 65560).

Parks. Land in public or private ownership that provides for passive and/or active recreation. Also see the definition for the various types of parks, i.e., Mini, Linear, Neighborhood, Community and Regional Parks. San Luis Obispo County provides parkland for public use.

Passive Recreation. Non-intensive recreational activities such as riding and hiking trails and nature study that require no more than limited structural improvements such as steps, fences and signs. (See also **Active Recreation**).

Pocket Parks. See **Mini-Parks**.

Policies. Policies are more specific than objectives. Policies are statements that guide decision-making and imply a clear commitment. Policies are based on the information gathered and analyzed during the preparation of this Element.

Production Agriculture. This term refers to the type of agriculture that qualifies for exemption from trail dedication requirements in this element. This is defined in the Agriculture and Open Space Element of the general plan (in Appendix J).

Public Facility Fees. See **Impact Fees**.

Quimby Fees. See **Impact Fees**.

Recreation. An activity that diverts, amuses, or stimulates an individual. Also see Active and Passive Recreation. San Luis Obispo County offers public recreation in its parks, recreation sites, natural areas, and golf courses. County recreation includes classes (such as yoga and aquatics), league sports play, hiking, biking, swimming, tennis, nature appreciation, and other activities that provide a mental or physical diversion from one's normal routine.

Recreation Center. See **Community Center**.

Recreation Sites. Recreation Sites contain a community center and/or a large, outdoor recreation facility (such as a swimming pool or skate park), that is not contained within a park. Recreation sites may also include some outdoor

recreation, and commonly include landscaping and parking. An example of a recreation site maintained by San Luis Obispo County is the San Luis Obispo Veteran's Memorial Building. This facility offers meeting rooms, music, dances, and an area for small conferences.

Recreation Programs. Recreation programs are classes, sports leagues and other organized activities offered through and managed by a city, county or non-profit. Examples of recreation programs offered by County Parks include yoga classes and summer swimming.

Regional Parks. San Luis Obispo provides two types of Regional Parks: Urban and Rural. Urban Regional Parks tend to be located near an urban area. Because of their location closer to population center, these parks may include some neighborhood and community park components as well as recreation generally associated with a Rural Regional Park (such as camping, trails and nature appreciation). Urban Regional Parks within San Luis Obispo County are generally larger than 25 acres. Examples of Urban Regional Parks in San Luis Obispo County include El Chorro and Biddle Parks. Rural Regional Parks tends to be located in a more remote area, i.e., away from urban development and population centers. These parks provide nature oriented recreation as well as items such as swimming, fishing, and boating. Generally a large proportion of a Rural Regional Park is set aside for conservation and resource management (natural areas). These parks are typically over 1,000 acres and tend to serve the county's population as well as a tourist population. Within San Luis Obispo County, examples of Rural Regional Parks are Santa Margarita Lake Regional Park and Lopez Lake Recreation Area.

Regional Trail. These are more ambitious projects, often part of a statewide campaign to improve long trail systems. In this county they include the California Coastal Trail, the Salinas River Trail and the Juan Bautista de Anza National Trail.

Sports Complex. These are athletic fields located to provide tournament and/or league play. The sports fields may include a variety of sports (e.g., soccer, baseball, softball, and football) or fields specifically for one type of sport. These complexes include parking, landscaping and often a concessionaire.

Trail. A pathway or route designed and constructed to carry pedestrians, bicycles, and/or equestrians and commonly prohibiting or restricting motor vehicle access.

Trail Corridor. A trail corridor identifies a swath of land within which a trail route is anticipated. A trail corridor provides flexibility in locating a trail and attempts to accommodate issues of terrain, sensitive resources, and land use, while providing some definition of the trail's location for planning purposes. The eventual trail route will only be a small portion of the indicated trail corridor.

CHAPTER 8: PARKS AND RECREATION PROJECT LIST

The Project List, as provided in this chapter, is the County's official list of park and recreation proposals. It is the policy of the County to implement the projects identified in this chapter through grant funding, capital improvement expenditures, or discretionary project review consistent with the objectives and policies contained within this element. This list will need to be updated from time to time. The Parks and Recreation Commission may make minor additions to the Project List, with the understanding that the ultimate approval and funding for a project resides with the Board of Supervisors. Deletions from the Project List can only be made by the Board of Supervisors. This insures that the most important park and recreation decisions are made at the highest level

Appendix A California Recreational Use Statute

CIVIL CODE DIVISION 2: Property PART 2: Real or Immovable Property TITLE 3: Rights and Obligations of Owners CHAPTER 2: Obligations of Owners

§846. Duty of care or warning to persons entering property for recreation; Effect of permission to enter

An owner of any estate or any other interest in real property, whether possessory or nonpossessory, owes no duty of care to keep the premises safe for entry or use by others for any recreational purpose or to give any warning of hazardous conditions, uses of, structures, or activities on such premises to persons entering for such purpose, except as provided in this section.

A "recreational purpose," as used in this section, includes such activities as fishing, hunting, camping, water sports, hiking, spelunking, sport parachuting, riding, including animal riding, snowmobiling, and all other types of vehicular riding, rock collecting, sightseeing, picnicking, nature study, nature contacting, recreational gardening, gleaning, hang gliding, winter sports, and viewing or enjoying historical, archaeological, scenic, natural, or scientific sites.

An owner of any estate or any other interest in real property, whether possessory or nonpossessory, who gives permission to another for entry or use for the above purpose upon the premises does not thereby (a) extend any assurance that the premises are safe for such purpose, or (b) constitute the person to whom permission has been granted the legal status of an invitee or licensee to whom a duty of care is owed, or (c) assume responsibility for or incur liability for any injury to person or property caused by any act of such person to whom permission has been granted except as provided in this section.

This section does not limit the liability which otherwise exists (a) for willful or malicious failure to guard or warn against a dangerous condition, use, structure or activity; or (b) for injury suffered in any case where permission to enter for the above purpose was granted for a consideration other than the consideration, if any, paid to said landowner by the state, or where consideration has been received from others for the same purpose; or (c) to any persons who are expressly invited rather than merely permitted to come upon the premises by the landowner.

Nothing in this section creates a duty of care or ground of liability for injury to person or property.

846.1. (a) Except as provided in subdivision (c), an owner of any estate or interest in real property, whether possessory or nonpossessory, who gives permission to the public for entry on or use of the real property pursuant to an agreement with a public or nonprofit agency for purposes of recreational trail use, and is a defendant in a civil action brought by, or on behalf of, a person who is allegedly injured or allegedly suffers damages on the real property, may

present a claim to the State Board of Control for reasonable attorney's fees incurred in this civil action if any of the following occurs:

- (1) The court has dismissed the civil action upon a demurrer or motion for summary judgment made by the owner or upon its own motion for lack of prosecution.
- (2) The action was dismissed by the plaintiff without any payment from the owner.
- (3) The owner prevails in the civil action.

(b) Except as provided in subdivision (c), a public entity, as defined in Section 831.5 of the Government Code, that gives permission to the public for entry on or use of real property for a recreational purpose, as defined in Section 846, and is a defendant in a civil action brought by, or on behalf of, a person who is allegedly injured or allegedly suffers damages on the real property, may present a claim to the State Board of Control for reasonable attorney's fees incurred in this civil action if any of the following occurs:

- (1) The court has dismissed the civil action upon a demurrer or motion for summary judgment made by this public entity or upon its own motion for lack of prosecution.
- (2) The action was dismissed by the plaintiff without any payment from the public entity.
- (3) The public entity prevails in the civil action.

(c) An owner of any estate or interest in real property, whether possessory or nonpossessory, or a public entity, as defined in Section 831.5 of the Government Code, that gives permission to the public for entry on, or use of, the real property for a recreational purpose, as defined in Section 846, pursuant to an agreement with a public or nonprofit agency, and is a defendant in a civil action brought by, or on behalf of, a person who seeks to restrict, prevent, or delay public use of that property, may present a claim to the State Board of Control for reasonable attorney's fees incurred in the civil action if any of the following occurs:

- (1) The court has dismissed the civil action upon a demurrer or motion for summary judgment made by the owner or public entity or upon its own motion for lack of prosecution.
- (2) The action was dismissed by the plaintiff without any payment from the owner or public entity.
- (3) The owner or public entity prevails in the civil action.

(d) The State Board of Control shall allow the claim if the requirements of this section are met. The claim shall be paid from an appropriation to be made for that purpose. Reasonable attorneys' fees, for purposes of this section, may not exceed an hourly rate greater than the rate charged by the Attorney General at the time the award is made, and may not exceed an aggregate amount of twenty-five thousand dollars (\$25,000). This subdivision shall not apply if a public entity has provided for the defense of this civil action pursuant to Section 995 of the Government Code. This subdivision shall also not apply if an owner or public entity has been provided a legal defense by the state pursuant to any contract or other legal obligation.

(e) The total of claims allowed by the board pursuant to this section shall not exceed two hundred thousand dollars (\$200,000) per fiscal year.

Impacts of Trails and Trail Use

Public access wins in court: more protection for landowners

California legal decision clarifies rights of those who permit recreational access.

By Marcia Grimm, California Coast & Ocean

The California Supreme Court made a 1993 decision for advocates of greater public access that address private property owners who permit public recreational use of their lands. In *Ornelas v. Randolph*, a rule of law that may have inhibited public use of private lands was clarified to provide greater protection of landowners from liability to those who may be injured on their properties.

The case broadened the application of California's 'recreation use' statute, Civil Code Section 846, with respect to the type of property affected. Enacted by the legislature in 1963 to encourage private landowners to allow the general public to use their lands for recreation, Section 846 provides those owners with immunity from potential liability to recreational users except under certain conditions.

There is no immunity (1) if the landowner willfully or maliciously fails to guard or warn potential users about dangerous conditions on the land; (2) if permission to enter the property is granted for consideration; or (3) where the injured party is expressly invited, rather than merely permitted, to enter the property.

In keeping with the legislative intent, the immunity applies only where the injured party entered the property for a recreational purpose -- it would not prevent a liability claim brought against a landowner by, a contractor, employee, or invited guest who is injured on the property.

While the language of the statute seems fairly clear, courts have applied additional limits to its application by holding repeatedly that the land in question must be "suitable" for recreational use. Most notably, they have been unwilling to grant immunity against injuries that occur on construction sites. The *Ornelas* case was brought on behalf of an 8 year old child injured when playing around farm equipment and, following the construction cases, the lower court declined to grant immunity. This time, though, the State Supreme Court firmly decided that no such exception exists. The statute does not distinguish between developed and undeveloped property or between urban and rural land, and there is no requirement that the site be in a natural condition. What matters is the use actually made by the person entering: if it is for a recreational purpose (and the statute otherwise applies), the owner is immune from liability regardless of the condition of the site.

This decision should be helpful both to private landowners and to public access proponents by eliminating uncertainties about whether any particular property is or is not suitable for recreation. Owners need not fear liability to recreational users or arguably "unsuitable" lands, and may thus be more receptive to public access that the users themselves find desirable and appropriate.

Marcia Grimm is chief counsel for the California Coastal Conservancy.

Appendix B Trail Standards

Pedestrian Trail Standards

A pedestrian trail is a route that is designed and designated for recreational pedestrian use or provided as a pedestrian alternative to vehicular routes. The hiking trail design should be developed for pedestrian use only, so that traffic along the trail does not conflict. The trail should be of sufficient width to screen out undesirable sights and sounds, and should offer a variety of scenery and terrain whenever possible.

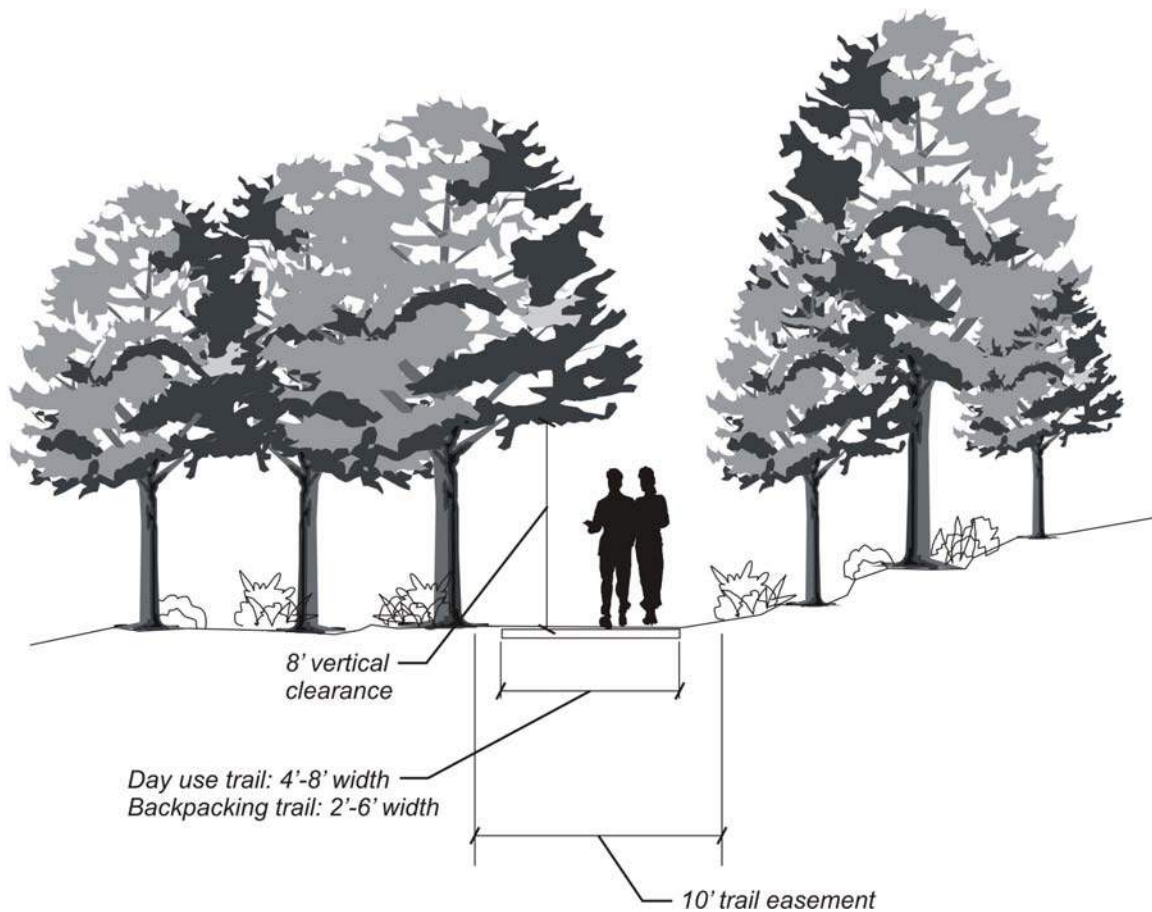

Trail Standards

Trail Tread Width: Day Use: 4-8 feet
Backpacking: 2-6 feet
(Trail generally narrows on steep slopes)

Horizontal Clearance: None required; trail meanders within easement

Vertical Clearance: 8 feet

Gradient: Desirable Grade: 0-5%
Maximum Sustained Grades: 25%
Maximum Sustained Grades for less than 50 yards: 40%
NOTE: Steps, switchbacks, water bars, or tread armor may be needed on slopes over 25%, depending on soil types.

Bridges: Placement: above high water mark
Width: Day Use: 2 feet – 6 feet
Backpacking: 2 feet – 4 feet



Signage: A Hiking Trail Sign should be visibly posted 6' to 8' high along the trail, illustrating that the sign is for pedestrian use only.

Bike Trails Standards

Bike Trails should be physically separated from motorized vehicles by an open space barrier and made for exclusive use by bicycles or pedestrians with cross-flow minimized. To be successful, bicycle paths should be designed to avoid conflict points with streets and other obstacles. Careful attention should also be taken regarding overall safety when paths are located in dangerous terrain. If there is enough right-of-way, bicycle paths should be at least 10 feet wide and optimally up to 20 feet in width if pedestrian use is expected. Paved, two-way bike trails should be delineated with a painted centerline stripe. Bike trails adjacent to a highway need to allow a 5 foot minimum clearance between the trail itself and the roadway edge of shoulder.

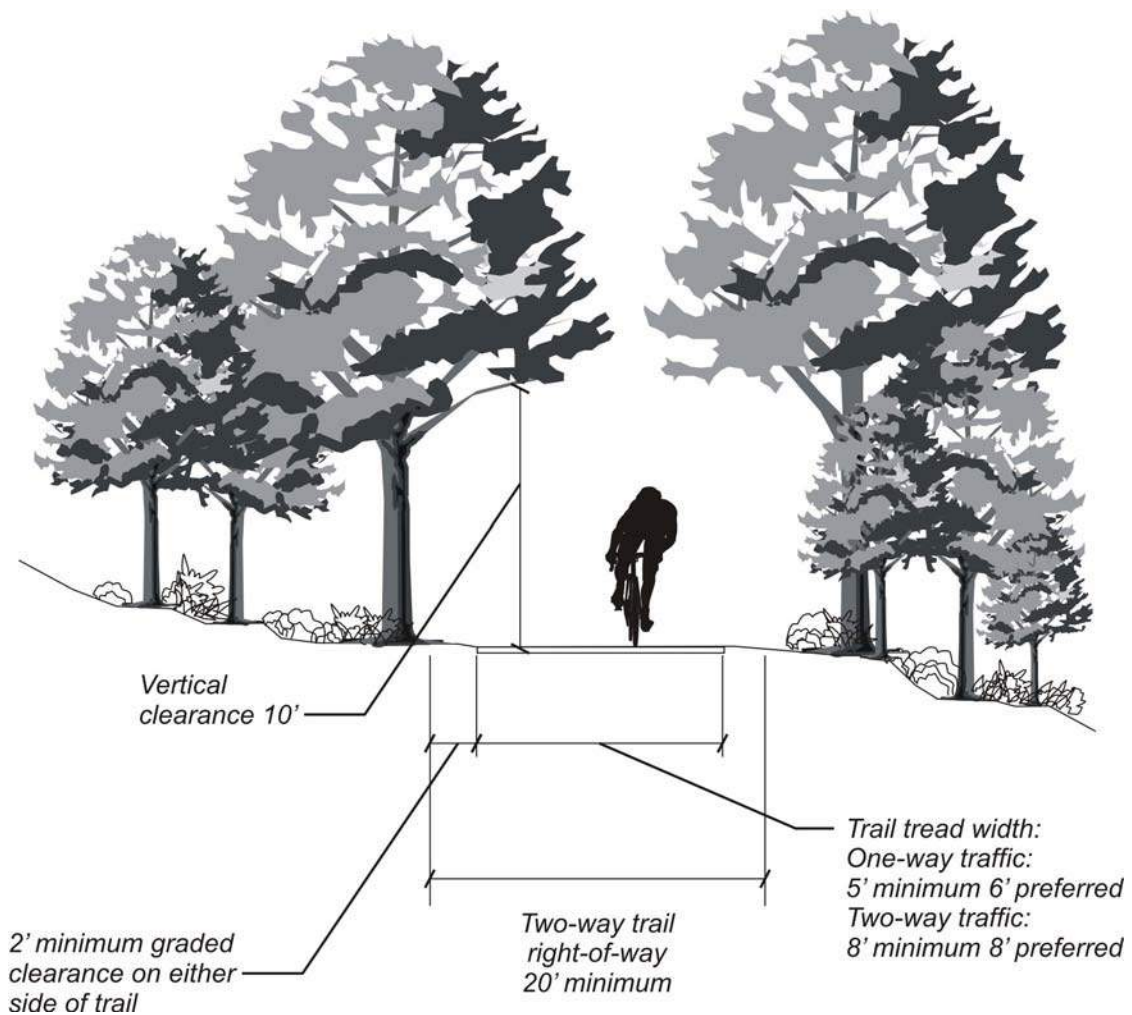

Trail Standards

Trail Right-Of-Way: 20 feet preferred, 10 feet minimum

Trail Tread Width: One-Way traffic: 4 feet minimum, 6 feet preferred

Horizontal Clearance: 2 feet

Gradient: Ideal: 0-3%
Maximum Sustained Grades: 8-10%
Maximum Short Distance: 15%

Sight Distance: 5 feet minimum, 100 feet preferred

Bridges: Smooth planking, straight approaches
Width: 8 feet
Capacity: 5 tons or depends on size of maintenance equipment

Underpasses: 10 feet x 10 feet

Compatible Uses: Hiking

Potential Use Conflicts: Horseback riding

Surfacing: Asphalt, limestone, lignin, etc, depending on availability of materials



Signage. Bike Trail signs should have 2 feet minimum lateral clearance from the edge of the path. The bottom of signs should be at least 7 feet above the trail. The signs should demonstrate the separation between bicycle and pedestrian use, if applicable.

Horse Trails Standards

The horse trail should have a 12' vertical clearance to allow for mounted riders throughout the trail. On trails where the corridor is wide enough, a separate horse trail alongside the bike/pedestrian trail usually works well and should be encouraged, but the horse trail should always be wide enough for pedestrians and horses to share (Min. 6'). The trailhead facilities must include parking lots for cars with trailers, toilets, information board, hitching posts, and tether lines.

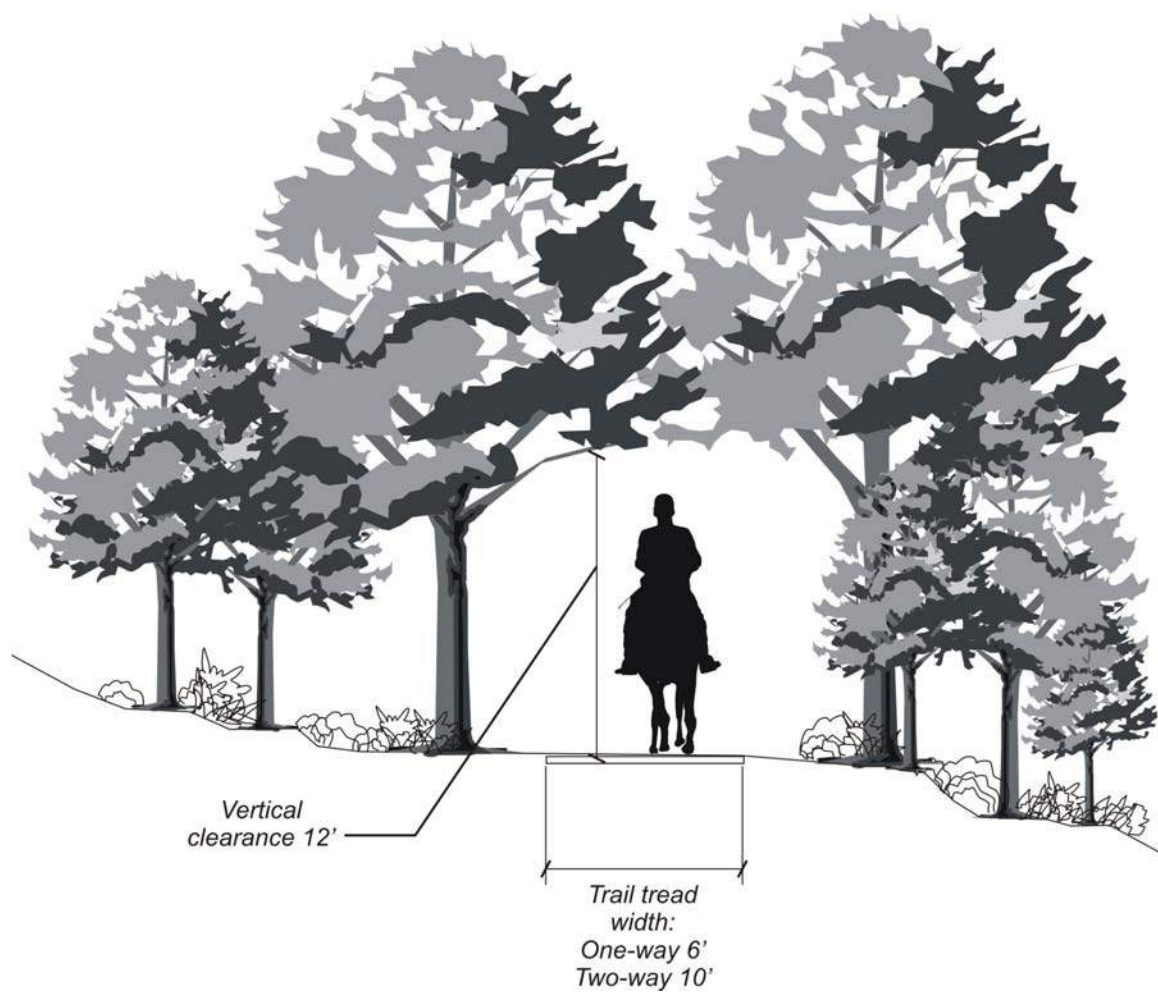

Trail Standards

Trail Tread Width: 6 – 10 feet

Horizontal Clearance: Trail width

Vertical Clearance: 12 feet

Gradient: Ideal: 1-10%
Max Sustained Grades: 10%
Max Sustained Grades for Less than 50 yards: 20%
Water bars and special surfacing may be necessary on slopes to prevent erosion.

Bridges: Placement: Above high water mark Width: 8 feet

Capacity: 5 ton, depends on maintenance equipment

Underpasses: 10 feet x10 feet culvert

Compatible Uses: Hiking (If not heavily used by horses)

Potential Use Conflict: Bicycling
(If proper line of sight and width are not available.)



Trail Signage: The Horse Trail Sign should be clearly visible, unobtrusive and stand 6 feet – 8 feet high with the Horse Trail symbol. If pedestrians are allowed, the sign should demonstrate how to share the horse trail.

Multi Use Trail Standards

A multi use trail may have originally been designed to provide a facility for bicyclists separated from other traffic, but trails often see greater use by pedestrians, joggers, and sometimes even equestrians. The planning and design of multi-use paths should therefore take into account the various skills, experience and characteristics of these different users.

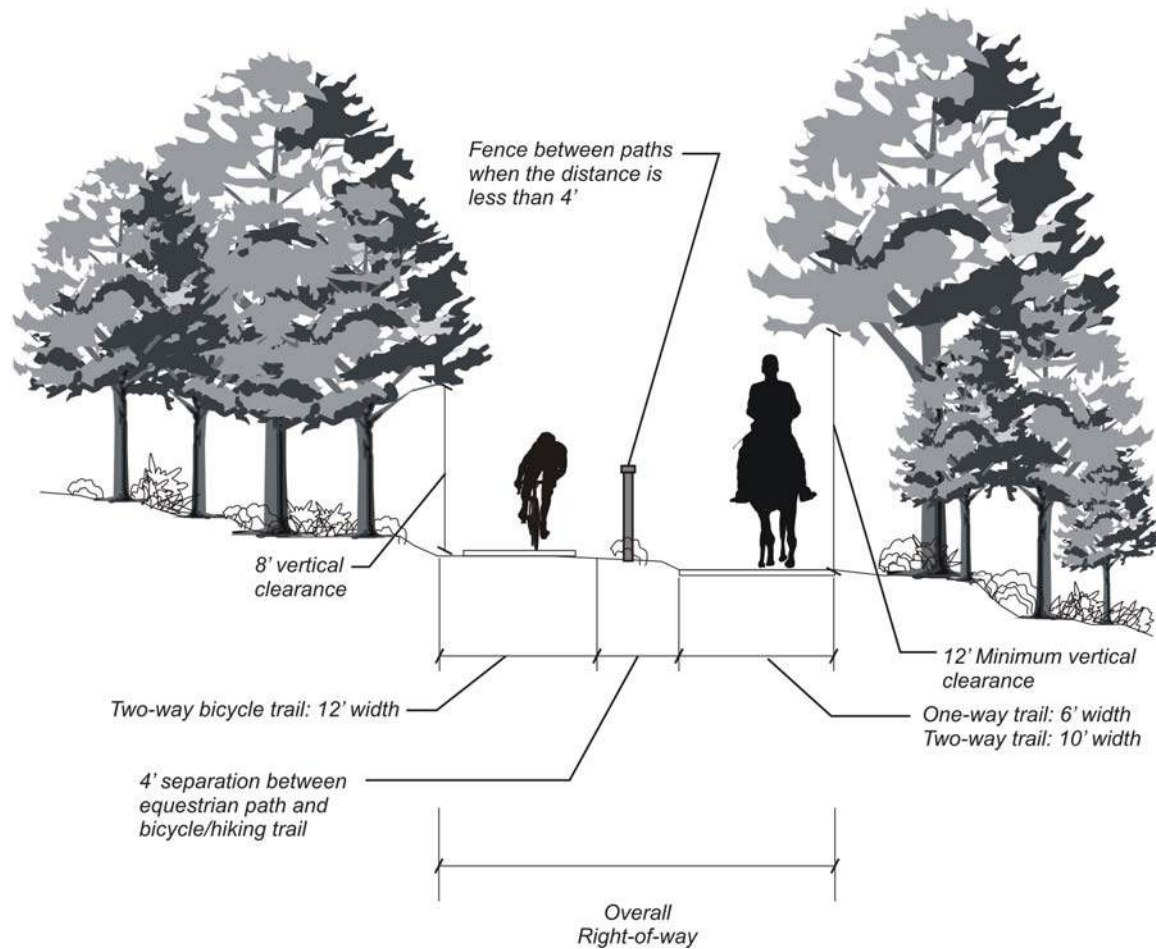

Trail Standards

Trail Tread Width: Pedestrian/Bicycle: to 6-12 feet
Horse: 6 feet to 10 feet

Overall Right of Way: 14 feet – 26 feet

Vertical Clearance: Pedestrian/cycling: 8 feet
Horse: 12 feet

Gradient: Ideal: 1-10%
Max Sustained Grades: 10%
Max Sustained Grades for Less than 50 yards: 20%
Water bars and special surfacing may be necessary on slopes to prevent erosion.

Buffer between pedestrian/bike path and horse trail: 4 feet

Fencing. A multi use trail should be divided with appropriate fencing. Two rail split rail fencing 3 feet high is recommended.



Two rail split rail fencing, 3 feet high

Trail Amenities Design Standards

Tree Planting

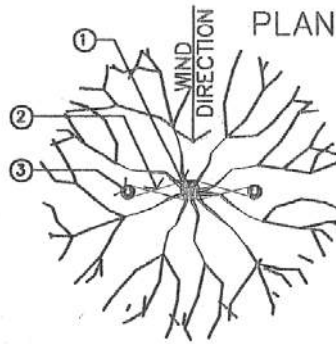
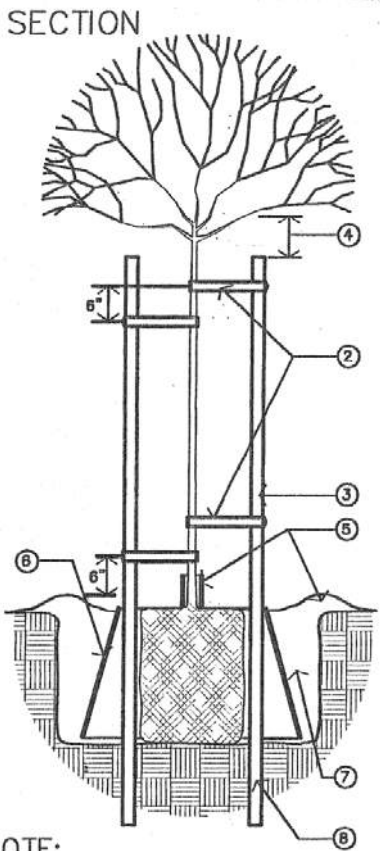

LEGEND:

- ① TREE TRUNK.
- ② V.I.T.'S "CLINCH TIES", FOUR REQUIRED. SECURE TIE TO STAKE WITH 6D GALVANIZED NAILS. (24"-15G., 18"-5G.)
- ③ 2" DIA. LODGE POLE STAKES, LENGTH AS REQUIRED.
- ④ PROVIDE 6" CLEARANCE—TREE BRANCHES TO TOP OF STAKE.
- ⑤ IN LAWN AREAS OMIT WATERING BASIN MOUNDS AND INSTALL V.I.T.'S "TRIM GUARDS" AROUND TREE TRUNK'S BASE.
- ⑥ INSTALL DEEPROOT'S NO. 22-30-18RP, DEEP ROOT BARRIER IN ALL PLANT PITS WHEN TREE'S WITHIN 8' OF PAVING.
- ⑦ BACKFILL PER SPECIFICATIONS, TAMP FIRMLY.
- ⑧ DRIVE TREE STAKES OUTSIDE OF ROOT BALL AND A MINIMUM OF 12" INTO UNDISTURBED SOIL.

NOTE:

- A. INSTALL TREE STAKES PERPENDICULAR TO WIND DIRECTION AND INSTALL PLUMB.
- B. REMOVE NURSERY STAKES.

Lodge Pole Fence Detail

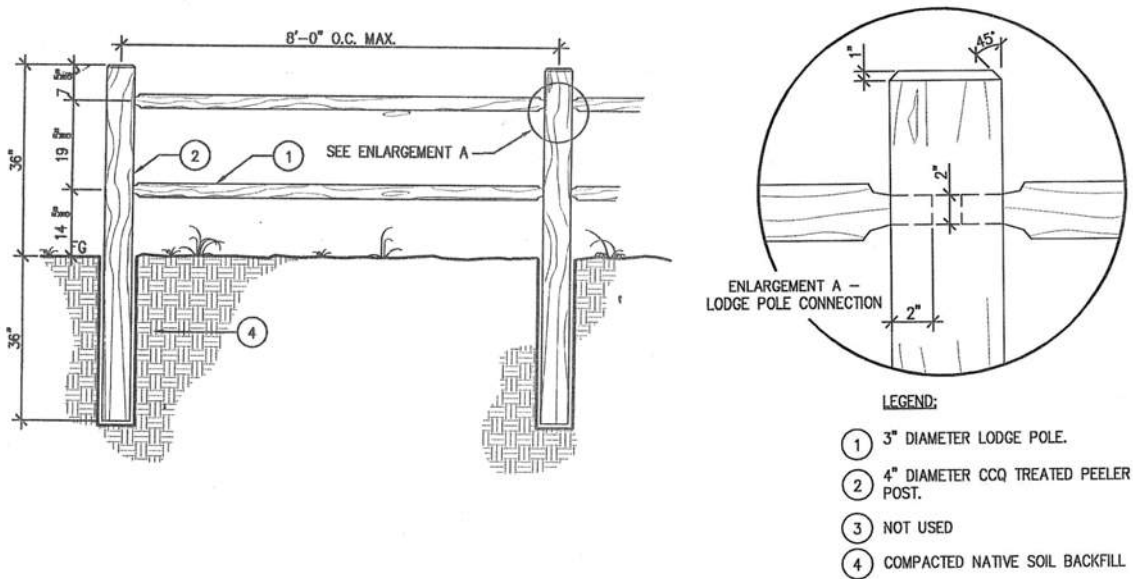

Sign Post Details

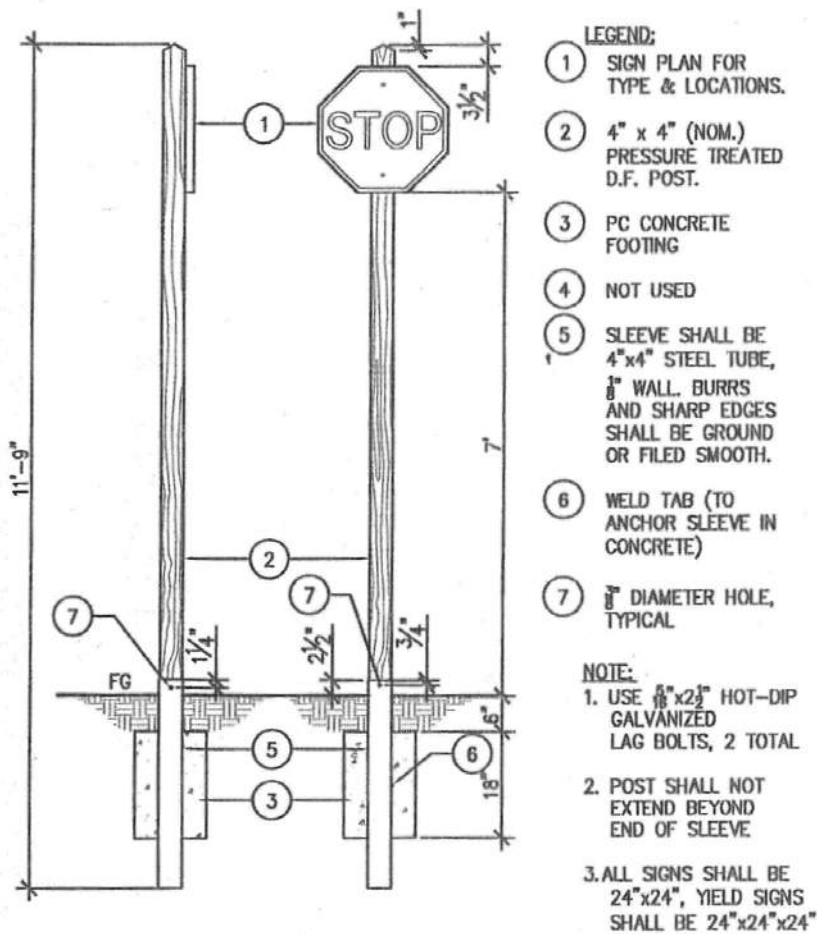

Log-In-Trail Erosion Control

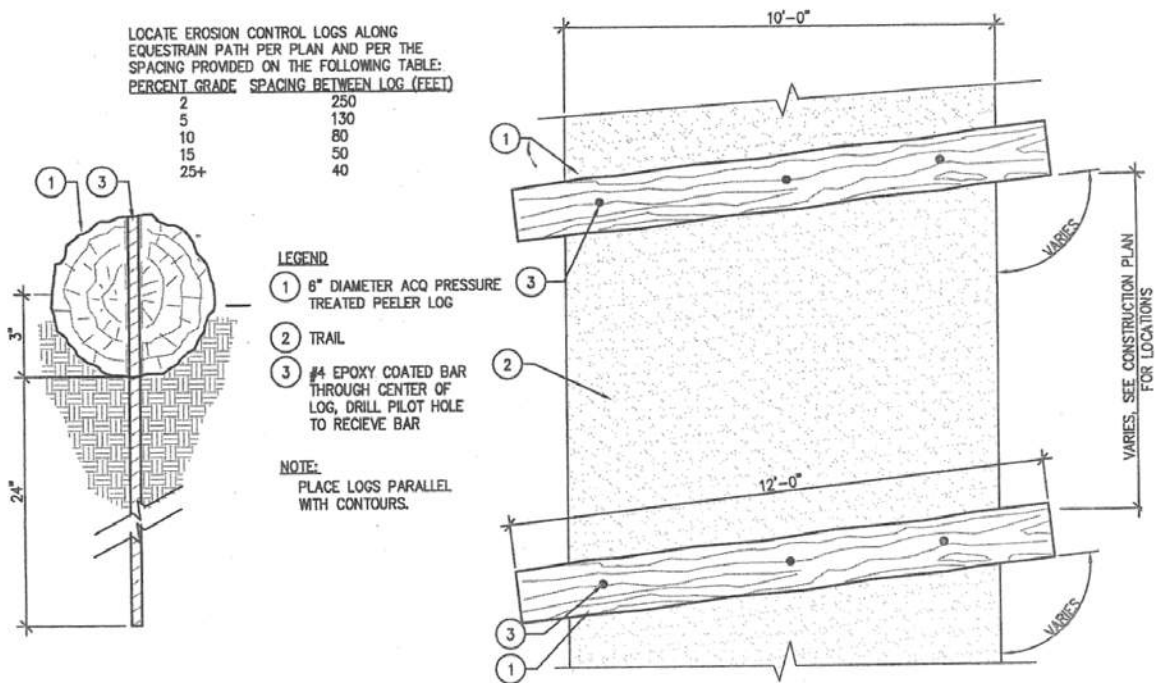

Bike Path Striping Details

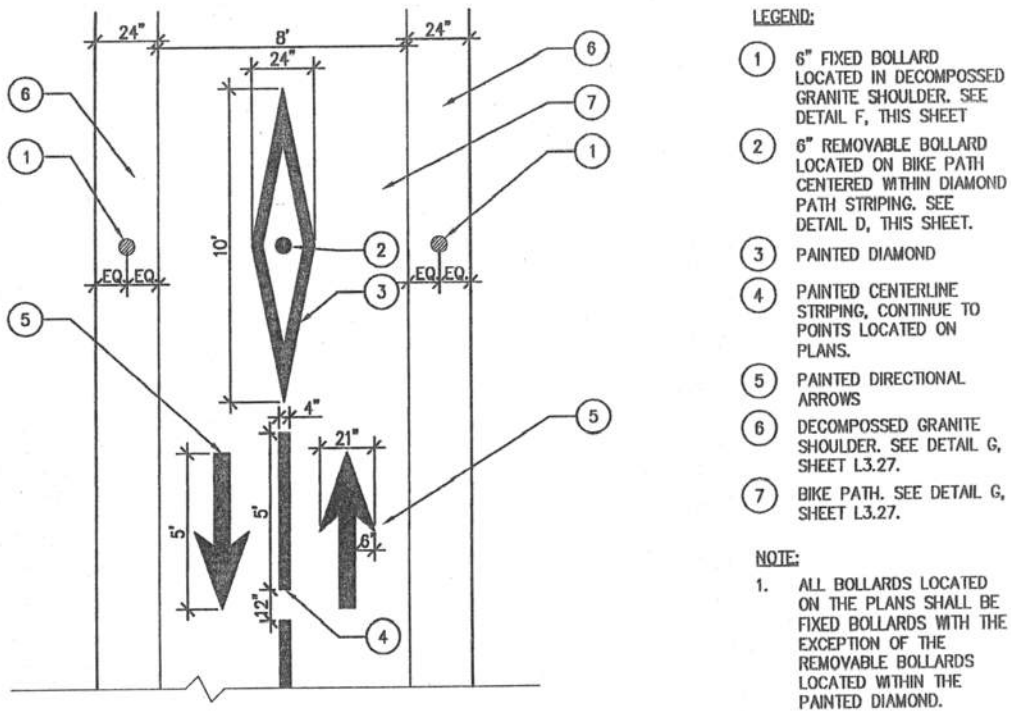

Removable Bollard Details

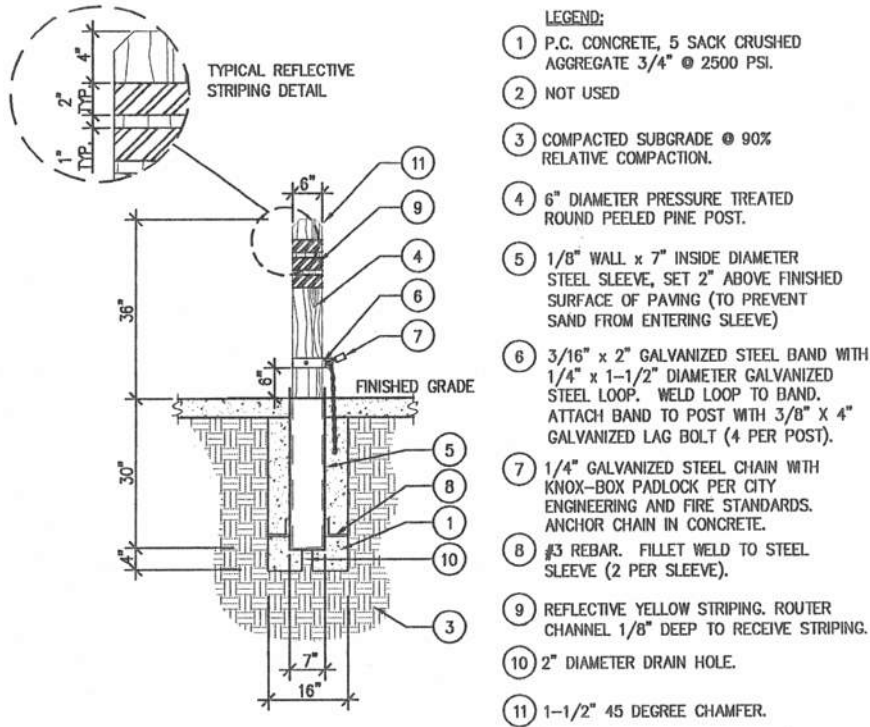

Decomposed Granite Path Section – Equestrian Path Details

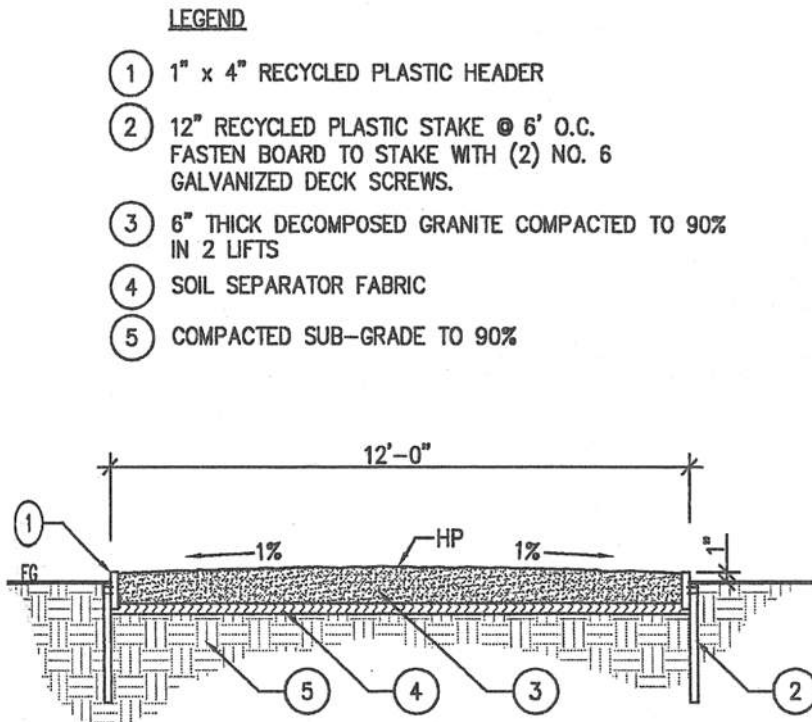

Multi-Use Trail Signs

A multi use trail should be signed with appropriate regulatory, warning and destination signs in addition to hiking, biking, and horseback riding signs.



MULTIPLE USE TRAIL GUIDELINES

TRAIL COURTESY & SAFETY ARE YOUR RESPONSIBILITY!

ALL USERS:

- OBSERVE RULES & REGULATIONS
- STAY ON DESIGNATED TRAILS
- BE ALERT AND COURTEOUS
- MINIMIZE YOUR IMPACT
- AVOID MUDDY AREAS



- Ride on open trails only
- Leave no trace
- Control your bicycle
- Always yield the trail
- Never scare animals
- Plan ahead.



- Control your horse
- Avoid cross-country riding.



- Yield trail to equestrians
- Allow equestrians and bicyclists to pass
- Don't cut switchbacks.

Appendix C Funding Sources

San Luis Obispo County Parks is constantly challenged to provide high quality services within the constraints of public finance. The financing of the proposals described in this Element will require a mix of available techniques to pay for park development and operations.

Existing Sources

The following are descriptions of existing funding sources currently used by the County to fund the Parks program.

- ⚙ **General Fund**
The General Fund can be used for all aspects of Parks financing including maintenance, staffing, acquisition and project costs.
- ⚙ **Grants**
Grants are available from local, state and federal agencies as well as from foundations and corporations. Matching funds for grants can be provided by additional grant funding, volunteer hours, donations, in-kind services and/or other revenue sources. Grants are usually limited to capital projects and major maintenance construction; they typically may not be used for ongoing maintenance.
- ⚙ **Volunteers and Donations**
Financial support may be derived from the generosity of individuals and groups in the community. Donations from the community support recreation programs, improve facilities, and provide resources, including park sites.
- ⚙ **User Fees**
Certain park facilities are partially or fully self-supported by user fees. The County charges user fees for facility and services where those fees can be cost-effectively collected. User fees are charged for services such as use of regional parks, camping, reservation of ball fields and tennis courts, golf, boating access, swimming, and facility rental for special events.
- ⚙ **Concessions**
A concession is a lease or agreement to operate or provide a service within a County park. Concessions provide income and desirable visitor services. Examples include the Mustang Waterslides at Lopez Lake, and the marina stores at both Santa Margarita and Lopez Lakes.
- ⚙ **Developer Conditions**
A discretionary development permit issued by the County may condition a project to provide land, amenities, or facilities consistent with this Element. In addition, County Parks may serve as a bank (site) to accept a developer's mitigation, such as trees and habitat restoration, when appropriate.
- ⚙ **Enterprise Funds**
Enterprise funds are established to finance and account for the operation and maintenance of facilities and services which are self-supporting by user charges with the use of tax revenues. Lopez Lake is operated as an Enterprise Fund.

- ⚙ **Public Facilities Fees**
Public Facility Fees currently only provide funding for new community-serving recreation facilities. These fees could be expanded to include funds for the purchase and development of regional parks and trails by working cooperatively with the County's cities and special districts.
- ⚙ **Quimby Fees**
The Quimby Fees provide funding for the construction and rehabilitation of community-serving recreation. The Quimby Act specifies rules and regulations governing the use of these fees.
- ⚙ **Public/Private Partnerships**
Partnerships and collaborative agreements allow the County Parks to effectively and creatively expand park and recreation services to address a wide range of community needs. Such agreements allow project capital and maintenance costs to be shared by the partners. Working partnerships have been developed over the years between the County and local school districts, cities, and special districts. Effective partnerships can make more effective use of tax dollars.

Potential Sources

While not currently used to fund County Parks, the following is a partial list of funding sources used by other local jurisdictions to fund parks, recreation and natural areas. Many other sources not noted here could be considered.

- ⚙ **Transient Occupancy Tax (Bed Tax)**
Currently the County's transient occupancy tax (TOT) is imposed on individuals occupying any hotel or motel room or any rental (of less than 30 days). The majority of the county's transient occupants are tourists visiting the area many of which use the County's parks and recreation facilities. An increase or reallocation of the TOT could generate funds to maintain, develop and/or improve park and recreational opportunities.
- ⚙ **Formation of an Assessment District**
The voters could create one or more special districts to finance park acquisition, development, and maintenance. The guidelines for creating assessment districts are subject to change. One such option is the creation of a San Luis Obispo County Parks, Recreation and Open Space District.
- ⚙ **General Obligation Bonds**
The voters could approve a general obligation bond to finance needed park improvements. This option could be considered as a means to pay for a major share of land acquisition, capital improvements and rehabilitation of the park system outlined in this Element.
- ⚙ **Sales Tax**
An increase in the sales tax could allow funding to be directed toward the acquisition and/or maintenance of park properties.

Appendix D Capital Project Rating Criteria for San Luis Obispo County Parks

1. Will this project improve health and safety conditions? (0-5 points)
0=No impact on health/safety; 3=Provides moderate public health benefits or improved public safety; 5=Project is legally mandated.
2. How effectively does this project impact existing park and recreation service levels? (0-5 points)
0=No change to existing service programs; 3=Adds moderate enhancement to service levels; 5=Necessary to maintain current service levels.
3. How effectively does this project meet community recreation needs? (0-5 points)
0=No impact on community recreation; 3=Provides moderate reduction of unmet recreation needs; 5=Provides significant reduction of unmet needs.
4. Are there additional resources available to aid in the implementation of this project (i.e., grants, inter-agency or public/private cooperation)? (0-5 points)
0=Only County Park fund/resources available for project;
3=Partnerships/contributions available for approximately 60% of project costs;
5=Most project costs borne by others.
5. What is the project's impact on County Park's operating or staff costs? (0-5 points)
0=Project significantly increases operating/staff costs; 2=Project has no impact on operating costs; 5=Project will significantly reduce ongoing expenses.
6. Does this project meet identified, unmet need consistent with current plans and policies (i.e., the Park and Recreation Element, Natural Areas Plan, facility master plans, etc.)? (0 or 5 points)
0=Not identified in current plan or policy; 5=Identified in current plan or policy.
7. Is this project consistent with the balanced use of the various available County Park development funds (i.e., Public Facility Fees, Quimby Fees, general funds, etc.)? (0 or 5 points)
0=Project does not provide for balanced use of funds throughout county;
5=Project is consistent with balanced allocation of funds.
8. Will this project generate revenue? (0-5 points)
0=Will not contribute to any additional revenue; 3=Project costs will be recovered with 20 years; 5=Project costs will be recovered within 5 years.
9. Is this project required to make a committed project operational? (0-5 points)
0=Has no impact on other projects/facilities; 3=Complements a larger project improving level of service to public; 5=Project is required to make existing project functional.

Appendix E Consolidated Goals, Objectives and Policies

MISSION STATEMENT

The mission of the Parks Division is to ensure diversified opportunities for recreation and the personal enrichment of the county's residents and visitors while protecting its natural, cultural and historical resources.

CHAPTER 1 – PARKS DIVISION VISIONS FOR THE FUTURE

1. A quality park, recreation and natural area system.
2. An equitable distribution of parks and recreation lands and services.
3. Parks and recreation opportunities for all age groups and physical capabilities.
4. A system of parks, recreation and natural areas consistent with the community's existing and future needs.
5. Protection of sensitive natural and cultural resources within new and existing parks and natural areas.
6. A viable park, recreation and natural area funding source which provides for community needs.



Taking the canoe for a ride in Lopez Lake.

Parks Goal, Objective, and Policies

GOAL #1: An equitable and quality public park system within San Luis Obispo County.

OBJECTIVE A: Maintain and improve as well as provide new and expanded parks and recreation within the County consistent with Chapter 8 Parks and Recreation Project List, and the County's available funding.

Policies:

- 2.1 Provide parks which are aesthetic and consistent with community needs.
- 2.2 When acquiring parkland or considering the acceptance of a parkland donation give first priority to sites that would:
 1. Augment needed park or recreation opportunities as defined in this Element.
 2. Serve a good mix of users at a reasonable cost.
 3. Provide an appreciable amount of parkland or recreation as a result of being adjacent to a compatible site, such as a school.
 4. Allow development in a reasonable time period. The County should not obtain lands that have extensive permit and mitigation requirements that may conflict with the project's proposed use(s) or County policy.
 5. Serve an important existing or future need. The site should be able to be developed consistent with that need.
 6. Accommodate planned uses in terms of size, location, and existing constraints. The property should be largely devoid of constraints or hazards.
 7. Adequately accommodate long-term maintenance.
 8. Concentrate park acquisition efforts on sites larger than ten acres, except when (a) the proposal is for a linear park connecting important community components or providing key alternative transportation (such as a link between two schools), (b) a proposed park provides the only available park site in a community, (c) another agency will provide maintenance for the park, or (d) a smaller parcel has outstanding characteristics or unique features.

In general, projects that meet these criteria will be given a high priority.

- 2.3 When developing parkland:
 1. Prepare adequate studies to determine site constraints.
 2. Prepare and implement a master plan for the site.
 3. Provide reasonable buffers between existing uses and the new park facilities in order to reduce impacts.
 4. Use joint use opportunities and adopt-a-park programs as they are available.
- 2.4 Preserve County parkland for active and passive recreation. Community facilities, which have little to no recreational component, should be placed outside of an existing or proposed park.
- 2.5 Encourage private development of parklands and facilities, to assist with meeting park needs.

Recreation Goals, Objectives and Policies

GOAL #2: Recreation that serves the County's residents and visitors, various age groups, varying economic situations and physical abilities.

GENERAL RECREATION:

OBJECTIVE B: Provide new and expanded recreation within the County consistent with Chapter 8 Parks and Recreation Project List, and the County's available funding.

Policies:

- 3.1 To provide an equitable distribution of recreation throughout the County, County Parks should attempt to provide new or expanded recreation (as a first priority) in those Planning Areas that have:
 1. Experienced faster growth rates.
 2. Very limited existing park acreage and/or recreation opportunities in relation to population density. When assessing existing park acreage and/or recreation opportunities consider parks and recreation offered by all entities provided that entity offers comparable service to the County's unincorporated population.
- 3.2 Provide recreation at the County's parks consistent with community needs.
- 3.3 Seek joint use agreements, volunteer and other partnership opportunities to augment recreational services and reduce project costs.
- 3.4 When considering the acceptance or development of capital intensive recreational facilities such as community centers, indoor sports centers, and aquatic centers, attempt to get numerous entities involved to split the cost of acquisition, design, development, and maintenance.
- 3.5 Provide recreation programs at the County's owned or leased facilities which provide adequate cost recovery.
- 3.6 Recognize that many legitimate recreation activities are possible even through they may not be provided by the County. From bowling alleys to off-road vehicle courses, private enterprise offers a greater potential to supply various recreation needs. The County will work to assist private enterprise in providing these activities while at the same time it will work to ensure that they are appropriately located so as not to necessarily impact the environment or negatively burden surrounding land uses.

Trails

OBJECTIVE C: Provide a viable multi-use trail system which is protective of private property interests and public resources, and consistent with Chapter 8 Parks and Recreation Project List.

Policies:

- 3.7 County Parks shall consider as the highest priority those trail projects which:
1. Are on land owned or operated by the County, including public rights of way.
 2. Connect urban communities or provide access to recreation areas.
 3. Complete a trail corridor, where only small portions are missing.
 4. Will be popular due to their length or location.
 5. Offer alternative transportation.
 6. Solve a safety concern.
 7. Include a funding source.
 8. Minimize costs of development and maintenance.
- 3.8 To protect the interests of adjacent land uses (both public and private) and the environment, trail projects shall:
1. Be consistent with the standards in the General Plan including the County's Agriculture and Open Space Element.
 2. Stay as far away as reasonable from production agriculture, commercial activities and residences.
 3. Be built to minimize impacts to sensitive resources.
 4. Provide signs that identify permitted trail uses; directions to relevant public areas; and, provide for safety and protection of trail users and adjacent private property.
 5. Provide trail fencing where necessary to discourage trespass onto neighboring land and to protect sensitive resources.
 6. Impose enforceable limitations on the trail use, as appropriate.
 7. Be designed and constructed consistent with the trails standards contained in Appendix B of this document.
- 3.9 County agencies will work together to coordinate the development, maintenance and use of trails.

- 3.10 Extensive trail systems, such as the California Coastal Trail, the Juan Bautista de Anza and the Salinas River Trails, will generally be developed in a series of shorter, but viable, segments. Such segments shall not be constructed until a viable link can be established connecting residential communities, parks, staging areas, or other public points of interest.
- 3.11 Eminent domain will not be used for trail establishment.
- 3.12 Where public lands are not available or adequate to accommodate a public trail, a trail dedication in easement or fee across private property shall be considered and may be obtained only in the following instances:
1. From a willing seller or donor.
 2. As part of a New Town or Specific Plan that would create urban uses.
 3. As a condition of a project approval, subject also to Policy 3.13:
 - a. For land designated Agriculture when:
 - i. a general plan amendment would change the land use category from Agriculture to another land use category; or
 - ii. a discretionary project that would convert agricultural land to uses¹⁰ not related to agriculture; or
 - iii. a cluster subdivision would create eight or more residential parcels.
 - b. For land not designated Agriculture, but in production agriculture, when a discretionary project including a subdivision would convert land to uses¹¹ not related to production agriculture as determined by the County Agricultural Commissioner's Office.
 - c. For all other land not excluded under (a) and (b) above, for any discretionary project (parcel map, tract map, development plan, minor use permit, conditional use permit, etc.)
- 3.13 When a trail dedication is required as a condition of a discretionary permit, the required trail dedication must:
1. Be proportional to the level of development being proposed;
 2. Have an appropriate nexus to the effects of the permit;
 3. Be shown on an adopted plan or be a New Town or Specific Plan development as noted in Policy 3.12 (2) above;
 4. Result in no long term unmitigable environmental impacts; and

¹⁰These uses are limited to: religious facilities, libraries or museums, schools, commercial electric generating plants for the generation or distribution of electrical energy for sale, manufacturing, recycling facilities (excluding composting), residential care facilities, public safety facilities, commercial retail facilities (excluding restaurants and roadside stands), and waste disposal sites. These are defined in Titles 22 and 23 of the San Luis Obispo County Code.

¹¹ *ibid.*

5. Comply with all applicable local, state and federal laws and regulations.
- 3.14 Prior to the construction and/or County acceptance of a public trail corridor, the approving authority must make findings that:
 1. Sufficient funds are available for the trail's on-going maintenance; and
 2. The liability for the trail has been addressed pursuant to Policy 3.15.
- 3.15 The County shall fully indemnify, protect and hold harmless (including all costs and attorney fees) private property owners who dedicate or grant a public trail easement from, and against, those risks and damages that arise out of the usage of the trail easement by the public and which, in good conscience, should not be borne by the private property owner.
- 3.16 The County shall assure that if a public trail easement is abandoned, or if the liability acceptance is discontinued, the trail easement shall revert to the underlying property owner(s).

Golf

OBJECTIVE D: Provide a quality and affordable golf program at the County's golf courses.

Policies:

- 3.17 The County's golf courses should continue to be operated as an enterprise fund.
- 3.18 Each County golf course should have a master plan. New development at an individual golf course should be consistent with the project's master plan.
- 3.19 Land for new County operated golf courses should only be obtained and developed after completing a funding plan. The funding plan should assess various components including such items as the amount of existing rounds in the County (public and private), the amount of anticipated future rounds (public and private), and what populations the new course would serve.
- 3.20 Develop recreation facilities or opportunities (such as trail corridors) along the perimeter or interior routes of the County owned or operated golf courses where such corridors will not adversely impact golfers or jeopardize user safety.
- 3.21 Continue to use environmentally sensitive maintenance techniques at the County's golf courses.

Special Places Goal, Objectives, and Policies

GOAL #3: Maintain and augment access to and along the coast.

OBJECTIVE E: Provide a viable coastal access program through the County's coastal Area Plans and the Local Coastal Program.

Policies:

4.1 Continue to provide and maintain viewing areas, viewing platforms, vertical access, and lateral access along the County's beaches consistent with the County's coastal Area Plans and Local Coastal Program. Use joint use opportunities and adopt-an-access programs as they are available.

GOAL #4: Natural areas preserved within the County that protect unique and sensitive resources.

OBJECTIVE F: Provide natural areas consistent with Chapter 8 Parks and Recreation Project List, and/or the County's Agriculture and Open Space Element.

Policies:

4.2 When acquiring a natural area or considering the acceptance of a donation give first priority to sites that meet a majority of the following criteria:

1. Provide significant or locally important resource protection.
2. Would add important acreage to an existing County park or natural area.
3. Would allow for meaningful passive recreation, nature appreciation, and public education.
4. Would be better managed by the County than another entity due to its location or other factors. For small areas within a private subdivision, a homeowners association or similar entity should own and maintain areas set aside as mitigation.
5. Include a reasonable endowment fund or other funding mechanism/approaches for maintenance.
6. The site can be adequately protected and restored by the County or other organization or partnership.

In general, projects that do not meet these criteria should receive a low priority or not be accepted by the County.

4.3 When addressing changes in natural areas:

1. Be consistent with an approved master plan. Within the master plan include items such as environmental education, passive recreation, and methods for resource protection and restoration.
2. Provide adequate buffers between the natural area and adjacent urban or rural uses.
3. Seek joint use opportunities and adopt-a-natural area programs as they are available.

Choosing Parks and Recreation Goal, Objective, and Policies

GOAL #5: An equitable and realistic park, recreation, natural area, and coastal access Project List.

OBJECTIVE G: Determine a reasonable list of priority projects based on community needs, staffing, practical consideration of projects development potential, and funding.

Policies:

- 5.1 Project priorities should be determined by the County's rating criteria [Appendix D] and decision tree, and balancing staffing with community needs and funding.
- 5.2 When a County department provides or updates elements or other local plans (such as a design plan or bicycle plan), proposed projects (such as trails and parks, or road abandonment) should be referred to Parks Division and brought to the Parks and Recreation Commission for review and input before the document is taken to the County's Planning Commission or Board of Supervisors for review and approval.
- 5.3 Examine national and statewide trends then conduct countywide surveys every five to seven years to determine user needs and ascertain customer satisfaction. These surveys can help determine priority projects.
- 5.4 Projects the Parks and Recreation Commission determines as priorities should be indicated in the 5-year Capital Improvement Program as a means of coordinating the acquisition, improvement, and rehabilitation of County park facilities.
- 5.5 The parks and Recreation Commission may make minor additions to the Project List (Chapter 8), with the understanding that the ultimate approval and funding for a project resides with the Board of Supervisors. Deletions from the Project List can only be made by the Board of Supervisors.

Funding Acquisition, Development & Maintenance Goals, Objectives, and Policies

GOAL #6: A variety of funding sources to expand, acquire, develop, and maintain the County's parks, recreation opportunities and natural areas.

OBJECTIVE H: Develop a funding mechanism that provides for acquisition, development and maintenance of parks, recreation, natural areas, and coastal access, taking advantage of collaborative agreements and volunteers.

Policies:

- 6.1 List projects in the County's Capital Improvement Program.
- 6.2 Develop a funding program that balances community need with available revenues. Use an economic consultant to review existing costs and provide recommendations for a viable funding program. This program should consider the formation of a parks district.
- 6.3 The County should enact and maintain an ordinance pursuant to the Quimby Act that will require a dedication of land and/or payment of fees in lieu thereof, for park and recreational purposes as a condition to the approval of a tentative tract or parcel map for residential subdivisions.

Maintenance

GOAL #7: High quality park maintenance that is cost effective and environmentally sensitive.

OBJECTIVE I: Provide new or expanded public facilities consistent with available maintenance funding.

Policies:

- 6.4 Prior to accepting or developing a new park, County Parks shall determine the long-term maintenance and operating costs associated with the proposed project. The County shall not develop the park until adequate funds are available for maintenance.
- 6.5 Ensure that County parks receive a net benefit to the County park and recreation system when a park or recreation facility is impacted by private or quasi-public infrastructure and other easements.
- 6.6 Require new development adjacent to parks, recreation and natural areas to be designed to function with and enhance park resources. Adjacent, new private development should not detract from or use adjacent park or natural area resources for their own private use.

- 6.7 Conduct project maintenance consistent with a facility's master plan.
 - 6.8 When maintaining park, recreation and natural area facilities attempt to minimize signs and other structures that may impact the aesthetics of the facility.
 - 6.9 County Parks should not undertake maintenance responsibilities better handled by another body. For example, facilities within private development (such as mini-parks, basin parks, mitigation areas, open space, and short segments of trails) shall be maintained by a homeowner's association or a similar entity.
 - 6.10 If County maintenance funding is inadequate to provide all park types, concentrate new park acquisition on regional park lands since these parks serve the largest number of users and are the least costly for the County to maintain.
 - 6.11 Use methods within County Parks' facilities that reduce maintenance costs, such as the use of drought tolerant landscaping, solar oriented structures, structures with natural lighting during daylight hours, and stainless steel fixtures which have a longer lifetime and are more resilient to vandalism.
 - 6.12 Continue to assess ways of providing additional maintenance funding including:
 1. The periodic review of user fees.
 2. Ways to cut staff time.
 3. Additional ways to manage and use volunteers.
 4. Assessing options such as the formation of a parks district.
-

Appendix F Standard Mitigation Measures

PRE EIR

An Environmental Impact Report was prepared and certified for the Parks and Recreation Element. As a program document, the mitigations measures contained in the EIR were designed to apply to a broad range of future parks projects. These are set forth here to guide future environmental review and to provide consistency as future projects are developed.

Mitigation Measures

Geology/Hydrology

Design Considerations. Facilities, particularly components such as parking lots, trails, and the like, shall be sited and designed to minimize the potential for long-term erosion. Considerations shall include proximity to waterways, minimization of direct impacts to waterways, reducing the length of vertical runs (in the case of trails), surfacing options and limiting or directing pedestrian and bicycle access.

Construction Considerations. Facility construction shall be programmed so as to reduce the potential for erosion. Considerations shall include timing to avoid the wet season (generally October 1 through April 15), and limiting the extent of exposed area either through staggering project phases or through a rapid revegetation program. Any construction activity which will involve disturbance of one acre or more will require permitting through the RWQCB NPDES program. All necessary permits will be obtained prior to construction.

Operational Considerations. Facilities shall be maintained so as to minimize the potential for long-term erosion and to ensure rapid response to emerging erosion problems. Trails, and unsurfaced parking or staging areas, among other facilities, shall be inspected on an ongoing basis, at least prior to and after the rainy season, to ensure emerging erosion problems are addressed. Ongoing problems may require surfacing, facility closure, redesign, or revegetation.

Design Considerations. Facilities shall be designed to as to minimize the amount and rate of off-site runoff. Facilities shall incorporate, where necessary, appropriate and feasible, measures such as:

- Permeable paving or surfacing materials.
- Bioswales or linear depressions in lieu of hard pipe/single outfall options.
- Natural topographic features to direct/disperse flow.
- Conjunctive use of recreational facilities to direct and disperse flow.
- Vegetated buffers.
- Retention basins (dispersed, small/shallow basins are preferred to single, deep and large basins).
- Other energy-dissipating structures.

No matter the technology used, facility proposals shall provide sufficient stormwater infrastructure to minimize off-site increases in runoff volume or rate.

Construction Considerations. The construction program shall minimize temporary impacts to stormwater flow and drainage by incorporating best management practices. Available BMPs are numerous, and include, but are not limited to, staging area control measures such as proper stockpile maintenance, perimeter control measures such as straw wattle and sandbagging, and internal control measures such as temporary sediment basins. Activities subject to the NPDES permitting program will include these measures in their Stormwater Pollution Prevention Plan (SWPPP).

Operational Considerations. Facilities shall be operated in a manner which minimizes ongoing impacts to drainage patterns and water quality. The County shall ensure that all installed measures and technologies are maintained in proper function. Stormwater infrastructure shall be inspected at least prior to and after the rainy season to include functionality; any needed repairs or alternative measures shall be pursued as soon as possible following discovery.

Design Considerations. At the time of initial project consideration and design, the County shall consult FEMA's flood zone maps for San Luis Obispo County, or other acceptable resources, to determine whether all or part of the proposed project is located within the 100-year flood hazard area. The presence or absence of a flood zone will affect decisions regarding the type of facility to be proposed for a particular site. Certain facilities, such as trails, natural areas, and sports fields, may be desirable uses for areas subject to flood hazard. At a minimum, the facility will address flood control for the individual facility, through landscaping, swales, and other measures as discussed elsewhere.

Biology Resources

- **Design/Site Selection Considerations.** A biological report prepared by a qualified professional (unless the Environmental Coordinator determines that the report is unnecessary) that recommends measures to avoid, and if not possible, to minimize or offset impacts to sensitive resources. The required biological survey shall include:
 - Determination of baseline conditions and the locations and extent of major plant communities/habitat types and locations of special-status species;
 - Evaluation of the potential occurrence of sensitive plant and animal taxa at the proposed development site (related facilities, structures, and access roadways) and within the project area;
 - Identification of potential impacts to biological resources, focusing on impacts to special-status species and sensitive habitats; and
 - Development of a mitigation program to guide further study or to mitigate impacts.

Components of possible mitigation programs may include, but are not limited to:

Siting. Avoid known individuals of or habitat for sensitive plant and animal species. Do not install impediments (fences, structures, lighting) to wildlife corridors.

Signage. Along trails and throughout parks and recreational areas include signage displaying interpretive information and use regulations, including identification of sensitive habitat.

Access Limitations. Limit access to sensitive areas; do not extend trail networks or provide single trails in sensitive areas.

Construction Considerations. Individual facilities may have any number of temporary impacts to biological resources. If the biological assessment identifies sensitive species, habitat, or potential for either, limitations may be placed on construction activity. Limitations shall avoid or minimize impacts to sensitive resources. Particular limits, in addition to those provided by any permits, if necessary, may include, but are not limited to:

- Fencing of exclusion areas (riparian/wetland areas, sensitive plant populations) with highly visible temporary fencing prior to initiation of construction activity
- Timing of construction to avoid high water periods, nesting seasons, etc.
- Limitations on the duration/extent of grading to the extent feasible

In addition to any approvals required by other agencies (DFG, FWS), the ultimate construction activity program shall be subject to approval by the County Environmental Coordinator or her designee.

Operational Considerations. Long-term impacts include those from recreational users, and those from maintenance activities. Where sensitive species or habitat are identified, the County shall include in the aforementioned mitigation program long term measures intended to protect such resources, including, but not limited to:

- Guidelines for maintenance activities such as brush removal, removal of non-natives, and application of herbicides and pesticides which avoid or minimize such activities in areas of sensitive resources.
- Maintenance of trail facilities, including closing emerging informal paths and installation of boundaries, if necessary, where users are straying from the formal trails

Cultural Resources

Siting/Design Considerations. A preliminary cultural resources survey (including subsurface investigation if necessary) will be prepared by a qualified expert acceptable to the Environmental Coordinator to determine the extent and significance of archaeological and historical sites. If the survey identifies potentially significant resources, it shall recommend both short- and long-term mitigation measures, which may include avoidance of impacts, burial under sterile fill, and/or monitoring of earthmoving activities. The Environmental Coordinator may waive this requirement if impacts on cultural resources will be minimal, based on such factors as location, extent of development or earlier resource analyses. Mitigation measures shall reduce the potential for human access and disturbance of significant sites, unless a qualified archaeologist and the Native American Heritage Commission explicitly approve interpretive shelters and signs as appropriate in conjunction with development and/or public access near discovered sites.

- a. **Monitoring Significant Sites.** If the archaeological survey finds significant sites on the property (including areas used for burial) Native Americans from a tribe indigenous to the area shall be required to monitor any work located within those archaeological sites.
- b. **Resources Discovered During Grading or Construction.** If archaeological resources are unearthed during grading or construction, earth-disturbing work shall be suspended until an appropriate mitigation plan is established, subject to the review and approval of the Director of Planning and Building.

Agriculture Resources

Trails. Trails should be sited so as not to be adjacent to agricultural operations. Where necessary to prevent trespass, fences should be employed.

Traffic

Design Considerations. Facility entrance points and staging areas will be sited and designed so as to allow for adequate sight distance and turning movements. Adequacy is to be determined by the County based on the facility's location, user type and frequency, among other considerations. Depending on the type and location of facility, remedies for traffic safety concerns may range from setback from road curves to signalization of intersections.

Operational Considerations. Facilities shall provide adequate parking such that surrounding area streets are not adversely impacted.

Construction Considerations. Construction activities shall deploy signage, cones, and public notice, among other measures subject to the approval of the County Public Works Department, to minimize potential hazards

Air Quality

The following measures shall be applied as needed:

- Construction Considerations
- Maintain equipment and vehicle engines in good condition and in proper tune per manufacturers' specifications and APCD.
- Use electricity from power poles rather than temporary diesel- or gasoline-powered generators.
- Use methanol- or natural gas-powered mobile equipment and pile drivers instead of diesel if available.
- Use propane- or butane-powered on-site mobile equipment if available.
- Store volatile liquids in closed containers.
- No open burning of debris, lumber or other scrap permitted.
- Evaluate, prior to final construction approval, a particular project's risk of releasing significant quantities of diesel particulate emissions, using APCD Guidelines. Projects which may exceed acceptable thresholds may be required to install one or more pieces of filtering equipment and/or use emulsified fuels.

Dust Control

- Watered areas with vehicle traffic; minimum of twice daily
- Streets adjacent to the project site shall be swept as needed.
- Exposed areas, new driveways and sidewalks shall be seeded, treated with soil binders, or paved as soon as possible.
- Cover stockpiles of soil, sand and other loose materials.
- Cover trucks hauling soil, debris, sand or other loose materials.
- Sweep project area streets daily.
- Appoint dust control monitor to oversee/implement dust control.
- Contractor shall maintain continuous control of dust from construction.
- When wind creates dust, to generate nuisance complaints, Contractor shall suspend grading operations, and/or water.
- During construction, minimized amount of disturbed area.
- Onsite vehicle speeds should be reduced to 15 mph or less.

Noise

Siting/Design Considerations. Projects anticipated to be a source of crowd or event noise, particularly those with amplified sound systems, will require additional study and a permit from County Parks prior to final siting to ensure that the use is compatible with the surrounding environment. PA systems may be altered in a number of ways to minimize noise, particularly spillover noise.

Construction Considerations. Where construction activities will take place near sensitive receptors, the County Noise Ordinance for construction activities, which limits hours of operation, shall apply.

Public Services and Safety

At the time of project conception the County shall consult with CDF and the County Sheriff to ensure the design includes adequate access and safety provisions

At the time of project conception the County shall document hazardous materials of concern on a particular site, and shall consider remediation needs based on the type and extent of facility. If remediation is not feasible, the County may elect to limit access to a particular portion of the site or forego its use.

At the time of project conception the County shall document sufficient water availability for the type of facility proposed.

At the time of project conception, where facilities will be served by central wastewater systems, the County shall document sufficient capacity for the project.

At the time of project conception the County shall document adequate landfill capacity for the project.

Aesthetics

Siting/Design Considerations. All facilities shall comply with the following requirements to the extent feasible. Exceptions may be granted if the new structure, grading, or access road will not be visible from a scenic road or highway as designated by the county or the state.

Building location. Development, including access roads, shall minimize visibility as viewed from any designated scenic road or highway to the greatest extent practical. Alternative locations or standards may be approved where visual effects are reduced to an insignificant level or where visibility is desired.

- **Screening of New Development.** When screening is necessary to protect a sensitive visual resource, the following is appropriate. The site design shall use existing topographic features to the extent feasible. Where use of topography is not feasible, existing vegetation, new landscaping plants, berms and fencing may be used. Where feasible, the use of natural vegetation and/or landscaping shall take precedence over

berms or fences. In cases where vegetation is used, the design shall provide that at least 80 percent of the structure(s), as viewed from public rights-of-way, shall be screened by plants at maturity. New landscaping should use native species to the extent feasible.

- **Ridgetop Development.** New structures shall be located so that they are not silhouetted against the sky as viewed from public roads or the ocean.
- **Significant rock outcrops.** Grading and placement of structures shall occur at least 150 feet from bedrock outcroppings visible from public right of way.

Slope Limitations for Grading and New Structures. No grading or structures shall occur on slopes greater than 20 percent (except in the case of trails) unless the County finds that there is no feasible alternative or that by allowing such grading or structures, the overall impacts would be better minimized. Grading shall be designed so that landform alterations are minimized to the extent feasible and blend with the natural topography by following existing contours where feasible.

Building Height and Mass of new buildings as viewed from public rights-of-way shall be minimized to the extent feasible by using low-profile design and other methods. Colors shall not markedly contrast with the surrounding environment but should complement and be similar to colors of surroundings.

Light and Glare. Facilities shall be designed to minimize new light, except for the minimum required for safety. In general, lighting fixtures shall be downcast and hooded. Night lighting for active sports fields shall limit spillover visible at sensitive uses such as residences to the maximum extent practical. Use of glare-producing materials shall be minimized.